



# INTELLI-JAY

## INSTRUCTION MANUAL



P/No. PM535J/C4878L

## IMPORTANT SAFETY INFORMATION

Please read this manual thoroughly before use and store in a safe place for future reference.

### WARNINGS

- Explosive gases. Prevent flames and sparks. Provide adequate ventilation during charging
- Before charging, read the instructions
- For indoor use. **Do not** expose to rain
- For charging Lead Acid and LiFePO<sub>4</sub> batteries **only** (of the size & voltage specified in the specifications table)
- Always charge the battery on the correct voltage setting. Never set the charger to a higher voltage than the battery specifications state
- Disconnect the 240V mains supply before making or breaking the connections to the battery
- The battery charger must be plugged into an earthed socket outlet
- Connection to supply mains is to be in accordance with national wiring rules
- Do not attempt to charge non-rechargeable batteries
- Never charge a frozen battery
- If AC cord is damaged, do not attempt to use. It must be replaced or repaired by a qualified technician
- Corrosive substances may escape from the battery during charging and damage delicate surfaces. Store and charge in a suitable area
- This charger is not intended for use by persons (including children) with reduced physical, sensory or mental capabilities, or lack of experience and knowledge, unless they have been given supervision or instruction concerning the use of the appliance by a person responsible for their safety
- Children being supervised not to play with the appliance
- If the recreational vehicle is to be put into storage without power, please turn off the BATTERY MASTER SWITCH. If the recreational vehicle is to be put in to long term storage without power, disconnect ALL cabling from the battery
- The battery terminal not connected to the chassis must be connected first. The other connection is to be made to the chassis, remote from the battery and fuel line. The battery charger is then to be connected to the supply mains
- After charging/for temporary or permanent removal of the battery/s, disconnect the charger from the mains supply. Then remove the chassis connection and then the battery connection

# CONTENTS

|   |           |
|---|-----------|
| <b>1 Product Instructions</b> .....                                   | <b>4</b>  |
| 1.1 Overview  | 4         |
| 1.2 Features  | 5         |
| 1.3 Block Diagram   | 5         |
| 1.4 Water Tank Probe  | 6         |
| <b>2 Key Features and Functions</b> .....                             | <b>7</b>  |
| 2.1 Multiple Inputs   | 7         |
| 2.2 Battery Charger of Starter/Service Battery                        | 7         |
| 2.3 Vehicle Battery Charger   | 7         |
| 2.4 Power Supply Mode   | 8         |
| 2.5 MPPT Solar Charger Controller                                     | 8         |
| 2.6 Built-in DC-DC Vehicle Charger                                    | 8         |
| 2.7 Categorised Outputs   | 8         |
| 2.8 Battery Low Voltage Protection (BLVP or commonly known as an LVD) | 9         |
| 2.9 Battery Switch  | 9         |
| 2.10 Precise Battery Measurement                                      | 9         |
| 2.11 Night Mode   | 9         |
| <b>3 Structure and Installation</b> .....                             | <b>10</b> |
| 3.1 PM535J Power Management System                                    | 10        |
| 3.2 Water Tank Probe  | 12        |
| <b>4 Wiring</b> .....   | <b>12</b> |
| 4.1 System Components   | 12        |
| 4.2 System Schematic  | 13        |
| 4.3 Preparation   | 13        |
| 4.4 Connection  | 13        |
| <b>5 LED Indicators</b> .....   | <b>14</b> |
| 5.1 PM535J Master Unit  | 14        |
| <b>6 Operation</b> .....  | <b>15</b> |
| 6.1 Manual Switch   | 15        |
| 6.2 Remote Switch   | 15        |
| 6.3 Dip Switch  | 15        |
| 6.4 Operation of Awning and Slide-out                                 | 15        |
| 6.5 Maintenance   | 15        |
| <b>7 Trouble Shooting</b> .....                                       | <b>16</b> |
| 7.1 LED Indicators on PM535J  | 16        |
| <b>8 Specifications</b> .....   | <b>17</b> |
| <b>9 Add-on Accessories</b> .....                                     | <b>19</b> |
| 9.1 Projecta Accessory Range  | 19        |

# 1 Product Instructions

## 1.1 Overview

The PM535J Power Management unit is designed for caravans or motor homes.

It has the following functions integrated into the unit: battery charger, power supply, MPPT solar charge controller, DC-DC charger, fused distribution blocks, low voltage disconnect (LVD), water pump controller, hot water system controller, water tank indicator and battery monitoring.

It also supports a range of additional Projecta accessories including tyre pressure monitors, leveling sensors and lithium batteries. Using Projecta accessories ensures that each component is optimized to work with each other in a complete ecosystem and allows for easy diagnosis if any issues arise.

### SYSTEM COMPONENTS

- 1 Master Power unit
- 2 Display Screen/Monitor
- 3 Up to 4 water tank probes, based on monitor selection (not included)
- 4 Accessories cables

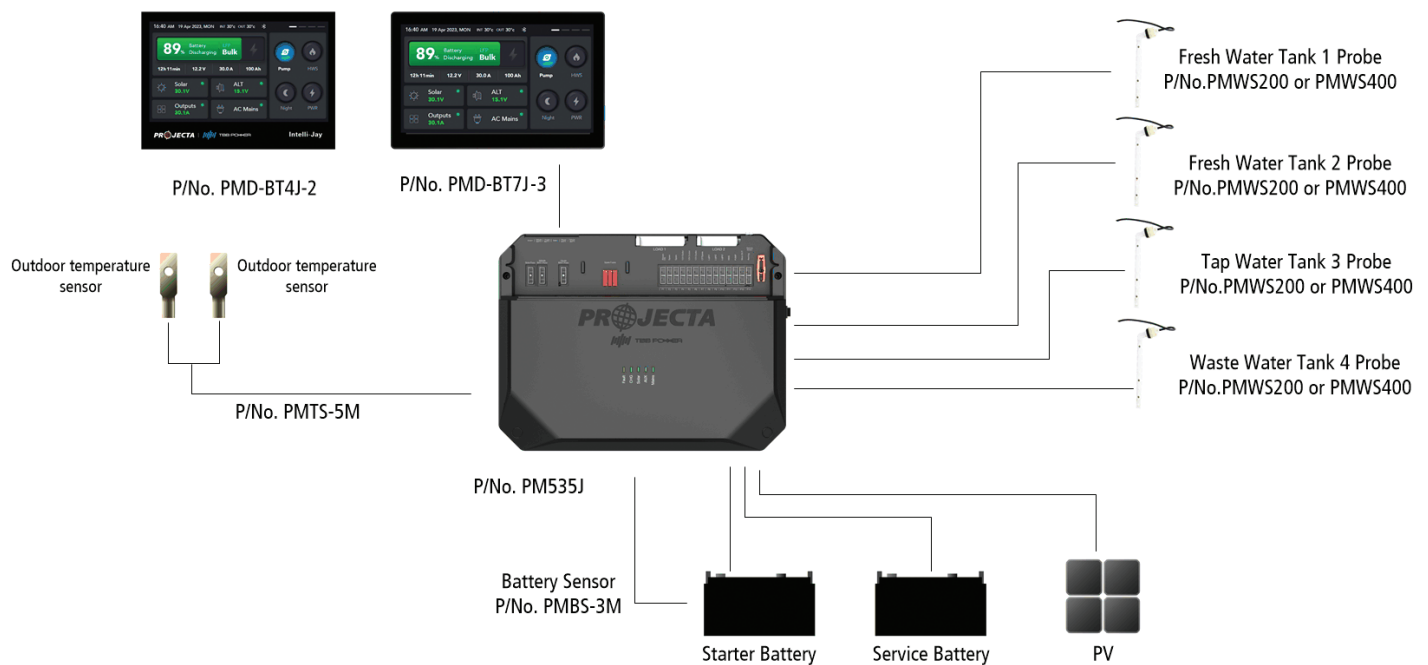

Figure 1 System Components

## 1.2 Features

PM535J has the following features

- Smart battery charger 12V 35A (35A for charging current)
  - Multistage adaptive charging algorithm
  - Active Power Factor Correction (PFC) charging
  - Temperature compensation charging
- Float charge for Starter/Vehicle battery
- 30A MPPT Solar charge controller
- Built-in DC-DC charger
  - 12V 30A continuous
- 14 built in fused outputs
- Battery low voltage protection
- Built-in battery switch to isolate the battery when in storage
- Built-in shunt for precise battery measurement
- Support for 4 water tank sensors
- Built-in Master Bluetooth for Bluetooth sensors
- RS485 & CAN compatible

## 1.3 Block Diagram

| CATEGORY | QTY | DESCRIPTION  | POSSIBLE USES            |
|----------|-----|--|--------------------------|
| Class A5 | 7   | Relay controlled output with fuse. Protected by main master switch relay | Water pump, HWS, TV etc. |
| Class C2 | 6   | Fused outputs, protected by master switch relay                          | Ventilation fan etc.     |
| Class D  | 1   | Permanent on load  | Auto sleep               |

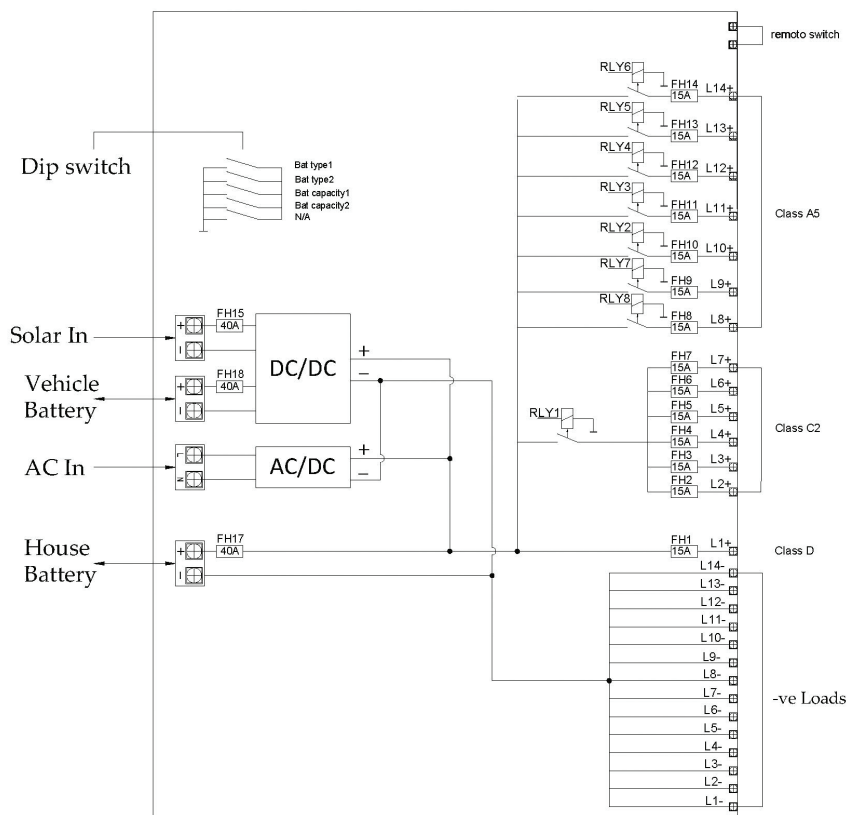

Figure 2 Unit Schematic

## 1.4 Water Tank Probe

PM535J can monitor a maximum of 4 water tank probes.

Note: Always check the probe required for the water tank before purchase. There are 2 probe styles.

### PMWS200:

- Side installation
- Suitable for water tank
- Depth > 200mm

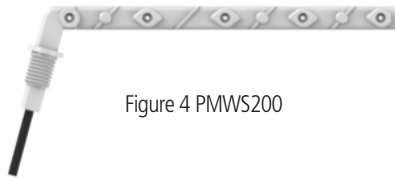

Figure 4 PMWS200

### PMWS400:

- Side installation
- Suitable for water tank
- Depth 300-400mm

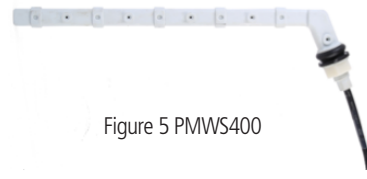

Figure 5 PMWS400

## 2 Key Features and Functions

### 2.1 Multiple Inputs

PM535J can support multiple charging sources at any one time. These sources include AC mains, Solar and starter battery (Vehicle). Charging priorities are listed within the table to the right.

|                   |          |          |          |
|-------------------|----------|----------|----------|
| AC MAINS          | X        | X        |          |
| SOLAR             | X        |          | X        |
| DC IN             |          | X        | X        |
| CHARGING PRIORITY | COMBINED | AC MAINS | COMBINED |

### 2.2 Battery Charger Of Starter/Service Battery

The charger automatically starts when the appropriate qualified power is connected, either from grid, alternator or solar.

With multiple charging stages (soft start-bulk absorption float & recycle), PM535J is designed to fully charge the service battery quickly.

PM535J features Microprocessor-controlled charging algorithms. The Float and Recycle charging programs ensure that the battery condition does not change despite being connected for a long period.

When the Charger is at Float Stage, if a new input source is added (AC Mains or Solar), the charger will return to the Bulk stage.

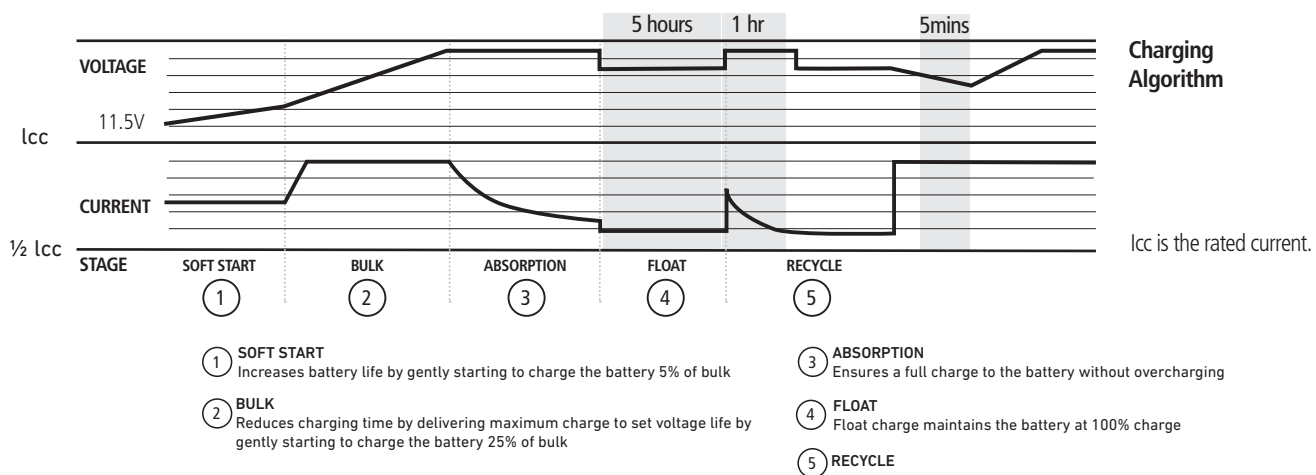

#### Battery Temperature Sensor

The battery temperature sensor (P/N: PMBS-3m) is used to measure the temperature of the battery, allowing the PM535J to adjust, in real time to charge the battery, at a compensation rate of  $-4mv \pm 10\%/^{\circ}C/cell$ . In installations where this sensor is not present, the PM535J will use  $25^{\circ}C$  as a default setting. The voltage sensor can automatically adjust its output to compensate the voltage drop caused by a cable. This ensures the right voltage is being delivered for optimal charging.

#### Voltage Compensation Charging

With a voltage sensor the PM535J can automatically adjust its output to compensate the voltage drop caused by a cable. This ensures the right voltage is being delivered for optimal charging.

#### Adjustable Charging Capacity

Users can adjust the charging current by specifying the battery capacity. The charging current is set at threshold rate of 10% the of the battery capacity ( $I = 0.1C$ ) by default

#### Lithium Battery Charging

The PM535J can be configured to charge Lithium batteries. The max charging current for lithium is automatically set at 30% of the battery capacity ( $I_{max}=0.3C$ )

### 2.3 Vehicle (Starter) Battery Charger

Along with a powerful charger for the service battery, PM535J offers a float charge of up to 3A to keep the starter battery topped up, whether connected to AC mains or PV (Solar). When the Vehicle battery is less than 12.4V, the PM535 starts charging after 30 minutes delay and stops charging when voltage reaches 12.8V

## 2.4 Power Supply Mode

If no battery is attached to PM535J unit, it will automatically work as a 35A power supply with a 12.8VDC output.

## 2.5 MPPT Solar Charger Controller

PM535J has a built-in MPPT charger for the House battery with:

- Max input voltage 42VDC
- Max charging current 30A
- Max supply current 30A

## 2.6 Built-in DC-DC Vehicle Charger

The PM535J main unit has an intelligent built-in DC-DC charging system that charges the battery via the alternator while the engine is running. The charging current is controlled according to the settings.

When the Vehicle/Starter battery reaches 12.8VDC with threshold time delay (4 seconds), the DC-DC charger will charge the Service battery from the alternator.

The DC-DC charger will continue charging until the Starter battery voltage drops under 12.0VDC (5 seconds).

The DC-DC charger also supports vehicles fitted with a smart alternator by using a D+ signal wire. With the D+ wire connected the DC-DC charger will work when the Vehicle/starter battery voltage is as low as 12.2Vdc and will continue charging until the alternator is switched OFF.

Installation of D+ signal wire:

1. For users with the 12-pin trailer connector from the vehicle, the D+ wire can be connected on pin 12 of the plug/socket.
2. For users without the 12-pin trailer connector – the D+ wire must be connected to the ignition circuit on the vehicle. It is also recommended that the vehicle is fitted with a VSR.

Note: all electrical wiring work needs to be a qualified electrician.

|                    | DC-DC TURN ON VOLTAGE (V) | DC-DC TURN OFF VOLTAGE (V) |
|--------------------|---------------------------|----------------------------|
| Without D+ connect | 12.8V                     | 12.0V                      |
| D+ connect         | 12.2V                     | 0V                         |

## 2.7 Categorized Outputs

The 14 outputs are categorised into groups and controls as per below:

| CATEGORY | QTY | DESCRIPTION  | POSSIBLE USES            |
|----------|-----|--|--------------------------|
| Class A5 | 7   | Relay controlled output with fuse. Protected by main master switch relay | Water pump, HWS, TV etc. |
| Class C2 | 6   | Fused outputs, protected by master switch relay                          | Ventilation fan etc.     |
| Class D  | 1   | Permanent on load  | Auto sleep               |

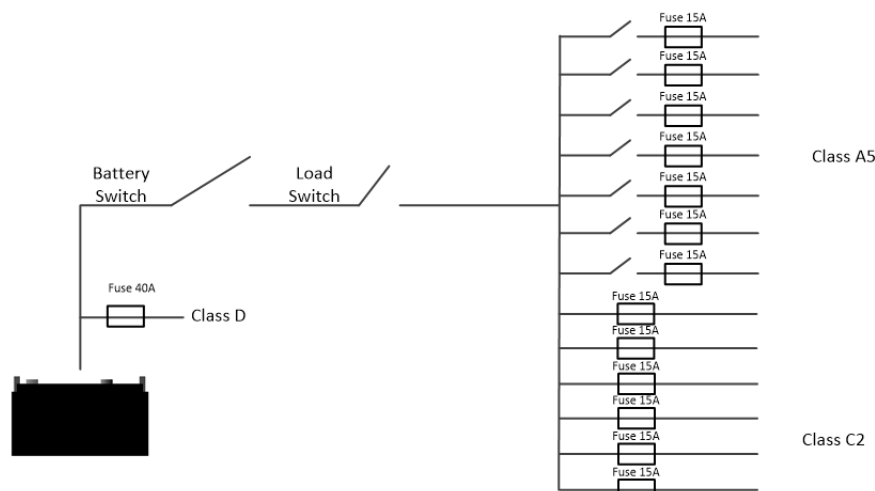

## 2.8 Battery Low Voltage Protection (BLVP or commonly known as an LVD)

The PM535J has a built-in low voltage protection relay. It will disconnect the load once the battery voltage drops below the threshold voltage. The default setting is 10.5VDC for AGM/WET(Default)/GEL and 11.6VDC for LFP. This switch can be manually turned On/Off via the LOAD button on the LCD display.

NOTE: Class C3 and Class D loads remain active.

## 2.9 Battery Switch

The PM535J offers a convenient way to switch off the output of the service battery on-board. It protects the service battery from being drained by electronics on board, completely isolating the battery. PM535J also supports a remote manual battery switch. Before using the remote switch, ensure the manual battery switch at the unit is set as "ON".

The switch is only effective when the system has no other input source for the load except the battery.

## 2.10 Precise Battery Measurement

PM535J has a battery measurement system controlled by microprocessor. It measures battery voltage, charge/discharge current, remaining battery capacity (in amp hours) and time remaining.

Compared to conventional indicating meters, a small current can be measured and read accurately with this device.

This feature highlights faults, alarms and installation errors.

NOTE: If you have loads connected directly on battery instead of the PM535J Power Management System, the measurement will not be accurate.

NOTE: P/No. PMShunt is required when heavy loads are used that are connected directly connected to non Projecta batteries. This ensures accurate state of charge. It is recommended to use Projecta's range of LB-HD batteries for seamless integration and accurate state of charge.

## 2.11 Night Mode

In Night Mode, the backlight of the monitor will turn off and the cooling fans will operate at a decreased speed. Charge current will be reduced to half rated selection when night mode is active.

### 3 STRUCTURE AND INSTALLATION

#### 3.1 PM535J Power Management System

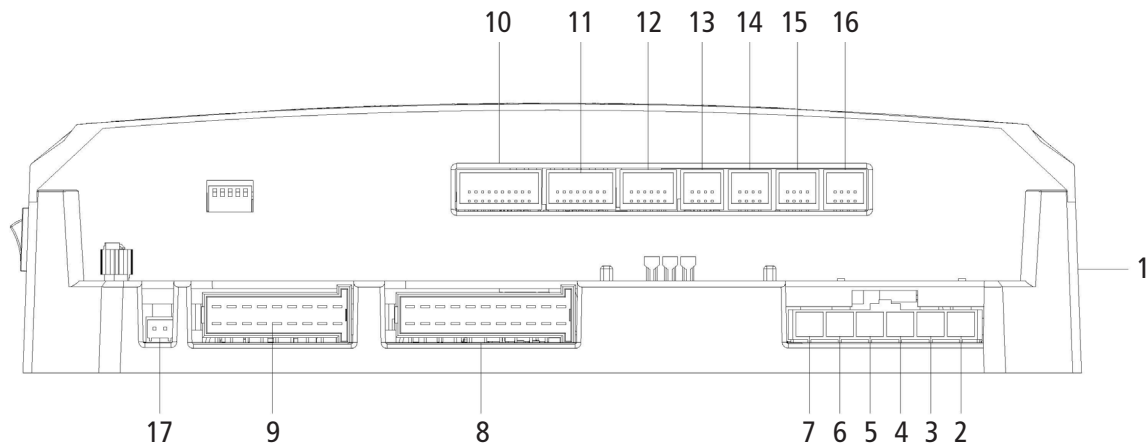

| N° | NAME                         | DESCRIPTION  | TYPE            |
|----|------------------------------|--|-----------------|
| 1  | AC Input                     | AC input   | IEC Socket      |
| 2  | Solar+                       | Solar input Positive   | Quick connector |
| 3  | Vehicle BATT+                | Vehicle BATT input Positive                                    |                 |
| 4  | House BATT+                  | House BATT input Positive                                      |                 |
| 5  | Solar-                       | Solar input Negative   |                 |
| 6  | House BATT+                  | House BATT+  |                 |
| 7  | Vehicle BATT+                | Vehicle BATT+  |                 |
| 8  | Load1                        | Loads  |                 |
| 9  | Load2                        | Loads  |                 |
| 10 | Battery Sensor / Dry contact | Battery sensor and 6 dry set contact                           | 20 pin socket   |
| 11 | Switch Panel / COMM          | IO COMM for LED panel and 485 COM for Power module and sensors | 16 pin socket   |
| 12 | LCD Monitor                  | COM for LCD monitor  | 12 pin socket   |
| 13 | Water1                       | 1 Water Tank   | 8 pin socket    |
| 14 | Water2                       | 2 Water Tank   | 8 pin socket    |
| 15 | Water3                       | 3 Water Tank   | 8 pin socket    |
| 16 | Water4                       | 4 Water Tank   | 8 pin socket    |
| 17 | Remote Switch                | Remote Switch (refer to 6.2)                                   | 2 pin socket    |

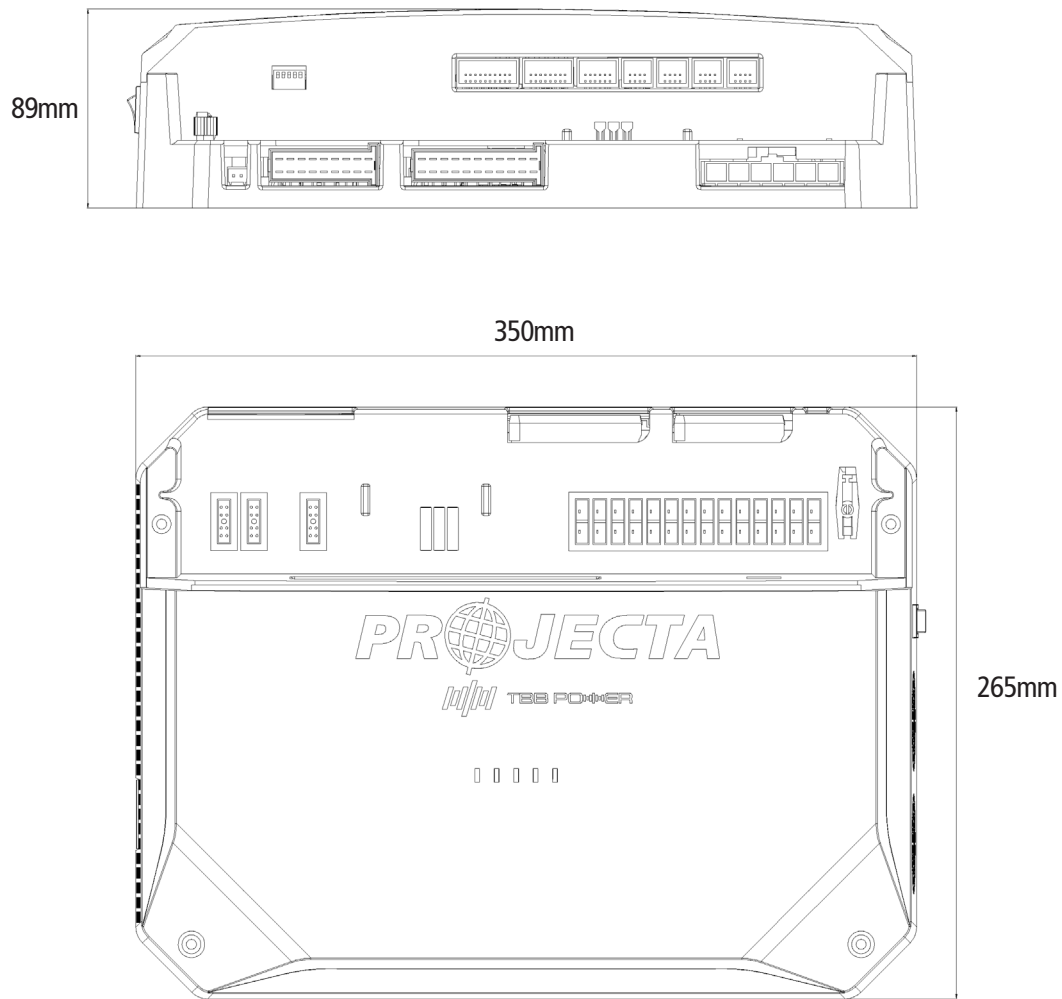

**Installation:**

PM535J adopts fan-forced air cooling for heat dissipation. To ensure effective heat dissipation, it is necessary to ensure that there is enough installation space. The installation space needs a minimum distance of 50mm on either side of the unit to keep the vents clear. It is also recommended that the installation space has adequate ventilation to ensure effective airflow.

Recommended vent size: 144 x 54mm

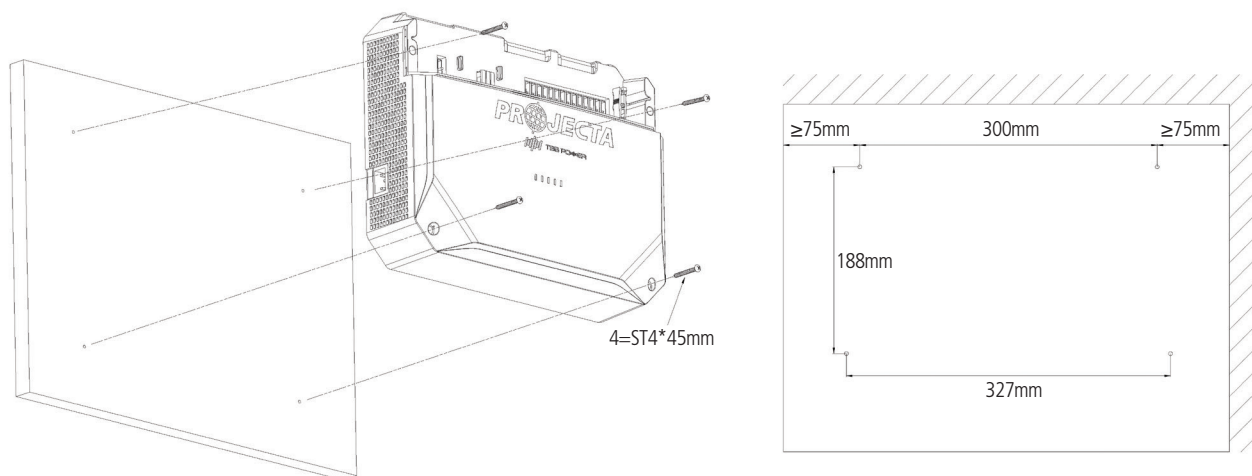

## 3.2 Water Tank Probe

### PMWS400 WATER TANK PROBE

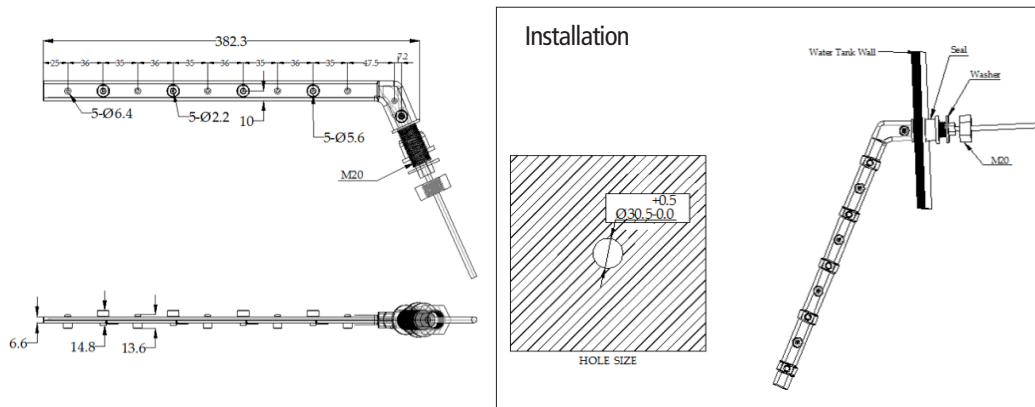

### PMWS200 WATER TANK PROBE

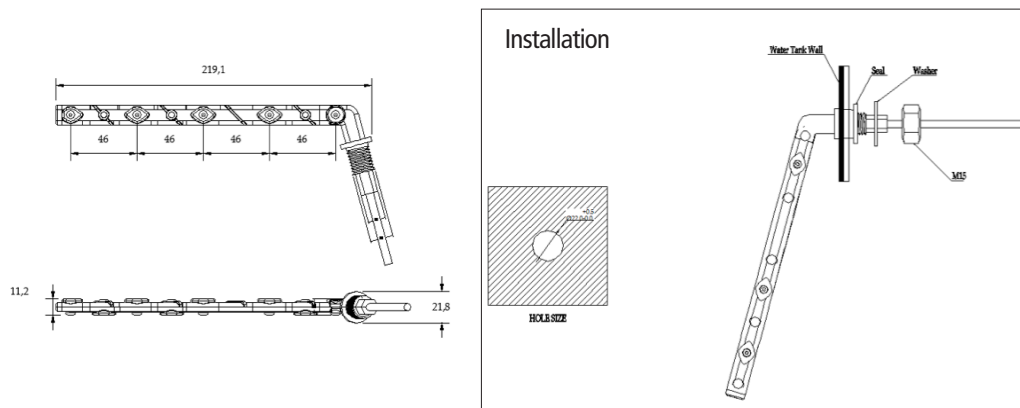

## 4 Wiring

### 4.1 System Components

| CODE | NAME                                      | MODEL/LENGTH            | QTY | P/NO. ON DRAWING |
|------|---|-------------------------|-----|------------------|
| 1    | Battery Management System                 | PM535J                  | 1   | 1                |
| 2    | Display Screen                            | PMD-BT4J-2 / PMD-BT7J-2 | 1   | 2                |
| 3    | Water Tank Level Sensor                   | PMWS200 / PMWS400       | 4   | 3,4,5,6          |
| 4    | AC Power Cable                            | 1.5M                    | 1   | PMAC             |
| 5    | Display Screen Cable                      | 5M                      | 1   | PMLCDC-7IN-5     |
| 6    | Battery Sensor Cable                      | 3M                      | 1   | PMBS-3M          |
| 7    | Indoor & Outdoor Temperature Sensor Cable | 5M                      | 1   | PMTS-5M          |

## 4.2 System Schematic

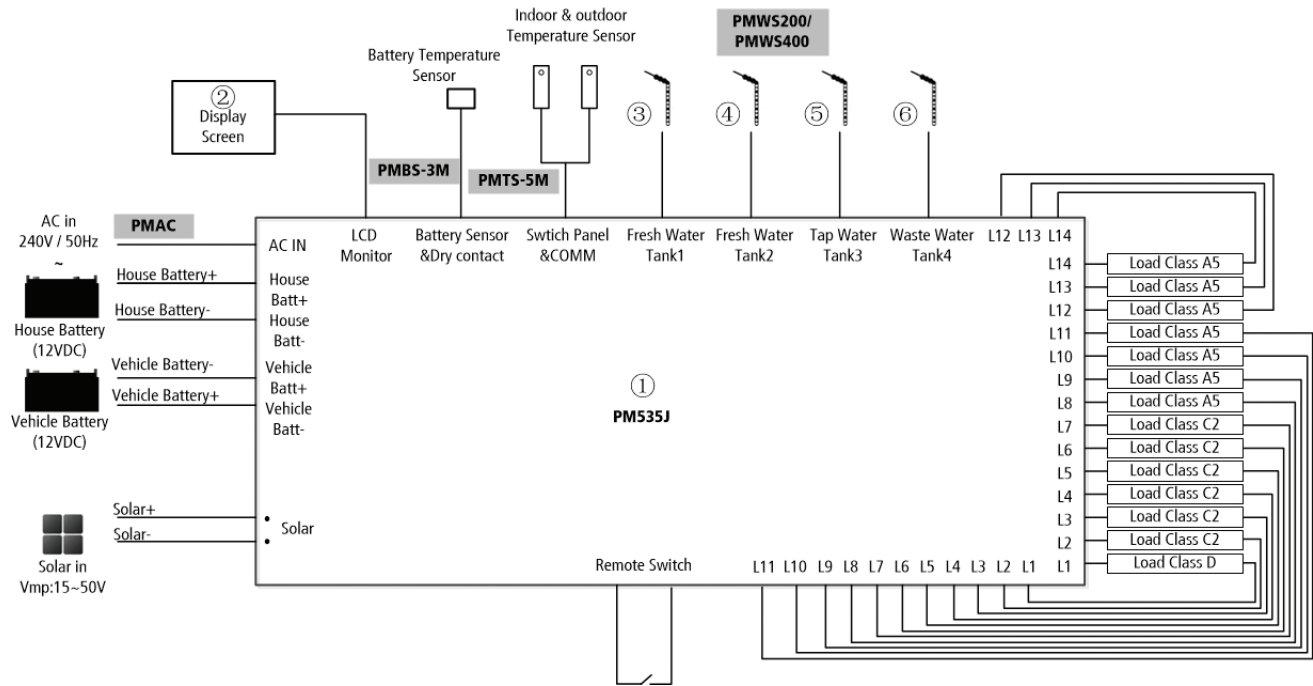

## 4.3 Preparation

PM535J is designed with ease of installation in mind. Follow recommendations in the table below for minimum wiring sizes.

| CURRENT | MINIMUM CABLE SIZE           |
|---------|------------------------------|
| 0–5A    | 1.0mm <sup>2</sup> or 18 AWG |
| 5–10A   | 2.0mm <sup>2</sup> or 14 AWG |
| 10–15A  | 3.0mm <sup>2</sup> or 13 AWG |
| 15–20A  | 4.0mm <sup>2</sup> or 11 AWG |
| 20–25A  | 5.0mm <sup>2</sup> or 10 AWG |
| 25–30A  | 6.0mm <sup>2</sup> or 9 AWG  |



When running cables, if they pass through panels or wall, ensure the cables are protected from damage by sharp edges. In such cases, it is recommended to use cable glands.

## 4.4 Connection

PM535J is designed with quick connect terminals. Please refer to illustration below.

Each type of terminal is designed to fit a different range of cable sizes.

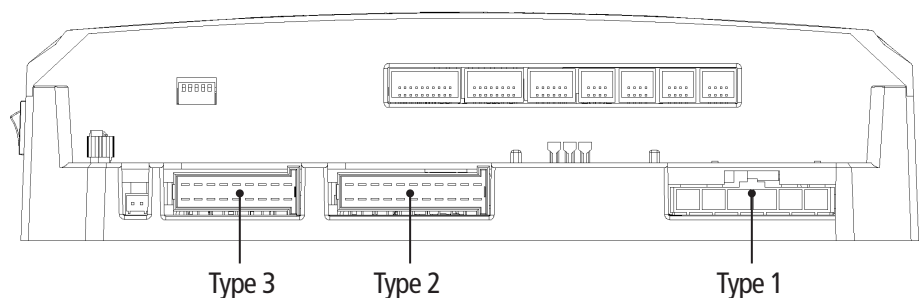

| TYPE   | MINIMAL CABLE SIZE | SUITABLE CABLE GAUGE                  |
|--------|--------------------|---------------------------------------|
| Type 1 | MOLEX 42820-6224   | 0.5mm <sup>2</sup> – 8mm <sup>2</sup> |
| Type 2 | TE 828801-7        | 0.5mm <sup>2</sup> – 3mm <sup>2</sup> |
| Type 3 | TE 828801-6        | 0.5mm <sup>2</sup> – 3mm <sup>2</sup> |

## 5 LED Indicators

### 5.1 PM535J Battery Management System



| NAME    | COLOUR                                 | STATUS                                    | DESCRIPTION  |
|---------|--|---|--|
| Mains   | GREEN                                  | ON  | AC input OK  |
|         |  | OFF                                       | AC disconnected  |
|         |  | Quick Flash                               | AC input abnormal  |
| AUX     |  | ON  | Vehicle battery charging the battery                               |
|         |  | Slow Flash (once every second)            | The input of the AUX is normal, but battery is charged by AC Mains |
|         |  | Quick Flash (twice every second)          | Vehicle Battery input error  |
| Solar   |  | OFF                                       | Vehicle Battery disconnected                                       |
|         |  | ON  | Solar charging the battery   |
|         |  | Slow Flash (once every second)            | The input of the AUX is normal, but battery is charged by AC Mains |
|         |  | Quick Flash (twice every second)          | Solar input abnormal   |
| CHG     |  | OFF                                       | Solar disconnected   |
|         |  | ON  | Battery charging - Float Stage                                     |
|         | Slow Flash (once every second)         | Battery charging - BULK, ABS Stage or VSR |  |
|         | Quick Flash (twice every second)       | Battery discharging                       |  |
| FAULT   | RED                                    | OFF                                       | Battery disconnected   |
|         |  | ON  | Short circuit  |
|         |  | 1 Flash                                   | House battery undervoltage   |
|         |  | 2 Flash                                   | House battery overvoltage  |
|         |  | 3 Flash                                   | Over temperature (Heat sink)                                       |
|         |  | 4 Flash                                   | Bulk charge time-out   |
|         |  | 5 Flash                                   | VSR abnormal   |
| 8 Flash | Over temperature (Unit)                |   |  |
| 9 Flash | Over temperature (PCB or Load circuit) |   |  |

## 6 Operation

### 6.1 Manual Switch

There is an ON/OFF switch on the side of the PM535J, which is used to disconnect the unit from the battery. If the unit is connected to AC mains and the switch is OFF it will also turn OFF the screen and charging. This switch must be "ON" for the Remote Switch to operate.

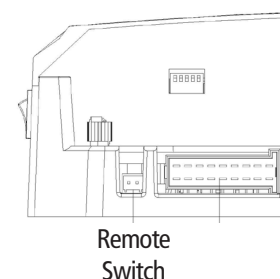
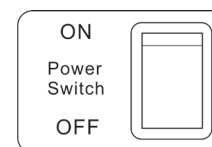

### 6.2 Remote Switch

The remote switch terminals are located next to the TYPE 3 connector on the left side of the unit. Refer to item 17 on the diagram on page 10. This can be wired to an external switch and functions the same way as the manual On/Off Battery Switch on the side of the charger. The Battery switch must be "ON" to use the Remote Switch line. When not used, both terminals must be bridged together.

### 6.3 Dip Switch

There is 5 pin dip switch panel on the unit which is used for adjusting charging current and battery type.

#### Pin 1-2 Definition

| 1   | 2   | Lead Acid |              | Lithium         |
|-----|-----|-----------|--------------|-----------------|
|     |     | AC Charge | Solar Charge | AC/Solar Charge |
| ON  | ON  | 10A       | 20A          | 30A             |
| ON  | OFF | 15A       | 30A          | 30A             |
| OFF | ON  | 20A       | 30A          | 30A             |
| OFF | OFF | 30A       | 30A          | 30A             |

#### Pin 3-4 Definition

| 3   | 4   | Type | Absorption | Float |
|-----|-----|------|------------|-------|
| ON  | ON  | WET  | 14.7       | 13.7  |
| ON  | OFF | LFP  | 14.2       | 13.5  |
| OFF | ON  | GEL  | 14.1       | 13.5  |
| OFF | OFF | AGM  | 14.4       | 13.5  |

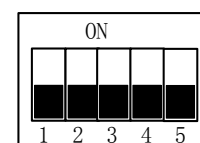

### 6.4 Operation of Awning and Slide-out.

To enable the awning and slide-out module, first disconnect the caravan from the towing vehicle, then turn on the load switch. This ensures that the safety inhibit feature, which prevents use while the vehicle is in motion, recognizes that the vehicle is no longer connected to the caravan and allows operation. If the caravan is not disconnected from the towing vehicle, the awning and slide-out outputs will remain inactive, even if the load switch is on.

### 6.5 Maintenance

#### BATTERY MONITOR MAINTENANCE

PM535J systems feature built-in battery measurement software. To ensure accurate readings, maintain the system with the following instructions:

- 1: Fully charge the battery from AC mains instead of solar every 2 weeks.
- 2: Fully charge the battery from AC mains at least once every 3 months, even in storage, unless required to earlier.
- 3: Charge the battery from AC mains until the "CHG" LED on PM535J unit or "Float" shows on the monitor.

#### DAILY MAINTENANCE

- Confirm the Power switch is turned ON when you want to charge the battery with AC mains.
- Check the nominal battery is 12VDC.
- Ensure there is enough space (50mm each side of the unit) for the appropriate ventilation.
- When replacing an existing battery, fully charge via AC mains to ensure SOC% is accurately calibrated.



Only the energy consumption of the loads connected on the PM535J are measured and calculated in the data on the Monitor.



For storage it is recommended to switch off the Manual Battery Switch on the unit or the Remote Switch (if installed) to cut off power to the system from the service battery.

NOTE: There may be some loads connected to the battery or constant output line (class D) that can continue to draw power.

## 7 Trouble Shooting

### 7.1 LED Indicators on PM535J

| NAME  | COLOUR | STATUS                           | DESCRIPTION   |
|-------|--------|----------------------------------|---|
| Mains | GREEN  | Quick Flash                      | AC input abnormal   |
| AUX   |        | Slow Flash (once every second)   | The input of the AUX is normal, but battery is charged by AC Mains                    |
|       |        | Quick Flash (twice every second) | Vehicle Battery input error   |
| Solar |        | Quick Flash (twice every second) | Solar input abnormal  |
| Fuse  | RED    | Solid                            | Fuse blown<br>- Need to check the device or cables and replace fuse                   |
| Fault |        | ON                               | Short circuit   |
|       |        | 1 Flash                          | House battery undervoltage<br>- Charge the battery                                    |
|       |        | 2 Flash                          | House battery overvoltage<br>- Charge the battery                                     |
|       |        | 3 Flash                          | Over temperature (Heat sink)<br>- Stop charging or Turn the Load switch off           |
|       |        | 4 Flash                          | Bulk charge time-out<br>- Reconnect the power source                                  |
|       |        | 5 Flash                          | VSR abnormal<br>- Restart the unit  |
|       |        | 8 Flash                          | Over temperature (Unit)<br>- Stop charging or Turn the Load switch off                |
|       |        | 9 Flash                          | Over temperature (PCB or Load circuit)<br>- Stop charging or Turn the Load switch off |

## 8 SPECIFICATIONS

| MODEL                            | PM535J                                |                                       |                   |
|----------------------------------|---------------------------------------|---------------------------------------|-------------------|
| <b>ELECTRICAL SPECIFICATIONS</b> |                                       |                                       |                   |
| AC Mains                         | Nominal input voltage                 | 240V $\pm$ 10%VAC<br>50/60Hz          |                   |
|                                  | Power factor                          | 0.95                                  |                   |
|                                  | Input current at full load            | 2.5A                                  |                   |
| Battery                          | Vehicle Battery                       | 12VDC                                 |                   |
|                                  | Vehicle battery voltage range         | 12.8-16VDC                            |                   |
|                                  | House battery                         | 12VDC                                 |                   |
|                                  | House battery voltage range           | 10.5-16VDC                            |                   |
| PV (Solar)                       | Charger type                          | MPPT                                  |                   |
|                                  | Open circuit voltage                  | 42VDC                                 |                   |
|                                  | Max supply current                    | 30A                                   |                   |
|                                  | Max charging current                  | 30A                                   |                   |
| DC-DC Charger                    | Relay specification                   | 12VDC 30A continuous                  |                   |
|                                  | Connect voltage                       | 12.8Vdc                               |                   |
|                                  | Connect delay time                    | 5 sec                                 |                   |
|                                  | Disconnect voltage                    | 12Vdc                                 |                   |
|                                  | Disconnect delay time                 | 5 sec                                 |                   |
|                                  | High voltage limit                    | 16VDC                                 |                   |
| Charger Mode                     | Charge algorithms                     | 5 Stages                              |                   |
|                                  | Battery type                          | AGM/GEL/LFP(LiFePO <sub>4</sub> )/WET |                   |
|                                  | Start voltage                         | >2A                                   |                   |
|                                  | Bulk current                          | 35A (Max)                             |                   |
|                                  | Absorption voltage                    | 14.4/14.1/14.2/14.7VDC                |                   |
|                                  | Float voltage                         | 13.5/13.5/13.5/13.7VDC                |                   |
|                                  | Maximum battery capacity              | 1200Ah                                |                   |
|                                  | Maximum battery quantity              | Dependent on battery capacity         |                   |
| Power Supply Mode                | Nominal output voltage                | 12.4VDC                               |                   |
|                                  | Rated output current                  | 35A (Continuous)                      |                   |
| Efficiency                       | 88%                                   |                                       |                   |
| Working Temperature              | -40°C to +60°C (40°C - 60°C derating) |                                       |                   |
| Battery Disconnect               | Disconnect voltage                    | Lead Acid                             | 10.5VDC (Default) |
|                                  |                                       | LFP (LiFePO <sub>4</sub> )            | 11.2VDC (Default) |
|                                  | Delay off time                        | 60 sec                                |                   |
|                                  | Reconnect voltage                     | Lead Acid                             | 11.5VDC (Default) |
| LFP (LiFePO <sub>4</sub> )       |                                       | 12.2VDC (Default)                     |                   |

|                                  |  |   |
|----------------------------------|--|---|
| <b>MODEL</b>                     |  | <b>PM535J</b>                                   |
| <b>ELECTRICAL SPECIFICATIONS</b> |  |   |
| Current draw on battery          | Only Battery and Load switch ON        | 700mA   |
|                                  | Only Battery and Load switch OFF       | 300mA   |
|                                  | Only Battery, Voltage < LVD            | 180mA   |
|                                  | Power Switch OFF                       | < 1mA   |
| Fused outputs                    | Quantity                               | 14  |
|                                  | Rated current                          | 15A   |
| Protection                       | Short circuit on outputs               | Fuse blown                                      |
|                                  | Reverse polarity                       | Diode reverse isolation                         |
|                                  | Overload protection                    | Derate the output until overload is removed     |
|                                  | Battery charger over temperature       | Shut down PM535J                                |
|                                  | Ambient over temperature               | Alarm   |
|                                  | Battery over voltage limits            | Battery charger disconnected, Load disconnected |
| <b>PHYSICAL SPECIFICATIONS</b>   |  |   |
| Dimension                        | 350mm*315mm*89mm                       |   |
| Weight                           | 3.3KG                                  |   |
| Enclosure                        | Metal & Plastic                        |   |
| Battery Connector                | Molex (42816-0612) (8mm <sup>2</sup> ) |   |
| Load Connector                   | TE 929504-7 (3mm <sup>2</sup> )        |   |
|                                  | TE 929504-6 (3mm <sup>2</sup> )        |   |
| Cooling                          | Forced cooling                         |   |
| Protection category              | IP20                                   |   |
| Approvals                        |  |   |
| Electrical                       | AS/NZS 60335.2.29                      |   |
| EMC                              | CISPR14                                |   |

## 9 ADD-ON ACCESSORIES

### 9.1 Projecta Accessory Range

The PM535J and PM635J support a range of additional Projecta accessories as listed below:  
For details on how to connect these, refer to the connection diagram.

#### SC520/SC540

#### 5 STAGE MPPT SOLAR CHARGER CONTROLLER WITH 100V INPUT

Get the most out of your solar array using these Maximum Power Point Tracking (MPPT) Solar controllers increasing the charging output by up to 30% (compared to PWM Solar controllers).



|                          | 20 AMP                             | 60 AMP |
|--------------------------|------------------------------------|--------|
| PART No.                 | SC520                              | SC540  |
| Battery Voltage          | 12/24/48V                          |        |
| Maximum Solar Voltage    | 100V                               |        |
| Standby Current          | 1mA at 12V, 3mA at 24V, 5mA at 48V |        |
| Charge Type              | 5 Stage                            |        |
| Input                    | 100V                               |        |
| Output                   | 20A                                | 40A    |
| Control Type             | MPPT                               |        |
| Batteries Supported      | GEL, AGM, Wet, Lithium             |        |
| Temperature Compensation | -18mV/12V                          |        |
| Communication            | RS485, Bluetooth                   |        |
| Storage Temperature      | -40 - 70°C                         |        |
| Humidity                 | 5 - 95%                            |        |
| IP Rating                | IP31                               |        |
| Weight                   | 1.4Kg                              |        |
| Cooling                  | Convection                         |        |

#### PMDCS30/PMDCS60

#### DC-DC 12V CHARGER

Smart DC to DC chargers specifically designed for Intelli-RV and Intelli-Grid.



|                          | 30 AMP                          | 60 AMP    |
|--------------------------|---------------------------------|-----------|
| PART No.                 | PMDCS30                         | PMDCS60   |
| Charge Type              | 5 Stage                         |           |
| Alternator Input Voltage | 12- 16V                         |           |
| Output                   | 12V, <30A                       | 12V, <60A |
| Batteries Supported      | GEL, AGM, Wet, Lithium          |           |
| Alternator Type          | Smart & Conventional            |           |
| Storage Temperature      | -40 - 70°C                      |           |
| Operating Temperature    | -40 - 70°C                      |           |
| Temperature Compensation | -3mV/°C/Cell                    |           |
| IP Rating                | IP20                            |           |
| Dimensions               | 181 x 148 x 52mm                |           |
| Weight                   | 1.0kg                           |           |
| Cooling                  | Convection                      |           |
| Smart Alternator         | Turn on 12.2V<br>Turn off 11.6V |           |
| Conventional             | Turn on 13.2V<br>Turn off 12.8V |           |

#### PMDCS30-20

#### DC-DC 12V CHARGER

Smart DC to DC chargers specifically designed for Intelli-RV and Intelli-Grid where a 3 way fridge or compressor fridge are used.



Note: If using load as a 'CONSTANT' connection (set via display or APP), the output of DCDC charger MUST be connected directly to LB-HD or PMSHUNT.

| PART No.                 | PMDCS30-20                      |
|--------------------------|---------------------------------|
| Charge Type              | 5 Stage                         |
| Alternator Input Voltage | 12- 16V                         |
| Output                   | 12V, <30A                       |
| Batteries Supported      | GEL, AGM, Wet, Lithium          |
| Alternator Type          | Smart & Conventional            |
| Storage Temperature      | -40 - 70°C                      |
| Operating Temperature    | -40 - 70°C                      |
| Temperature Compensation | -3mV/°C/Cell                    |
| IP Rating                | IP20                            |
| Dimensions               | 181 x 148 x 52mm                |
| Weight                   | 1.0kg                           |
| Cooling                  | Convection                      |
| Smart Alternator         | Turn on 12.2V<br>Turn off 11.6V |
| Conventional             | Turn on 13.2V<br>Turn off 12.8V |

## PMTPMS

### TYRE PRESSURE MONITORING SYSTEM MODULE

The Tyre Pressure Monitoring System (TPMS) monitors the RV's tyre pressure before and during the journey.



|                       |                                       |
|-----------------------|---------------------------------------|
| PART No.              | <b>PMTPMS x 4</b> (one for each type) |
| PART No.              | Receiver - <b>PMTPMS-R</b>            |
| Input                 | 6-24V                                 |
| Working Current       | 30mA                                  |
| Working Temperature   | -40°C - 85°C                          |
| Humidity              | <95%                                  |
| Receiving Frequency   | 433.910Mhz                            |
| Wired Communication   | RS48S                                 |
| Weight                | 150g                                  |
| PART No.              | Sender - 4 x <b>PMTPMS-S</b>          |
| Working Voltage       | 2.2 - 3.6V                            |
| Battery Type          | CR1632                                |
| Transmitted Current   | <5mA                                  |
| Transmitted Power     | <5dbm                                 |
| Transmitted Frequency | 433.910Mhz                            |
| Pressure Range        | 14 - 130PSI                           |
| Accuracy              | ±1.45 PSI                             |
| Working Temperature   | -30°C - 70°C                          |
| Weight                | 13.8g                                 |

## PMLVL

### LEVELLING SENSOR

Level the RV with the levelling sensor which can be monitored via the phone app.

#### Calibration

To calibrate the level sensor, the RV needs to be level in both forward and back and side to side. Once level, go to the Setting Page, select Level Sensor and press Calibrate. This will zero the sensor.



|                     |              |
|---------------------|--------------|
| PART No.            | <b>PMLVL</b> |
| Working Voltage     | 9 - 16V      |
| Working Current     | 30mA         |
| Working Temperature | -40°C - 85°C |
| IP Rating           | IP20         |
| Accuracy            | ± 2°         |

## LB200-HD

### 12V HIGH DISCHARGE 200AH LITHIUM BATTERY

LB200-HD boast impressive capabilities and are ideal for 4WDs and caravans with high power demands



|   |                   |
|---|-------------------|
| PART No.                                | <b>LB200-HD</b>   |
| Nominal Voltage                         | 12.8V             |
| Nominal Capacity                        | 200ah             |
| Nominal Energy                          | 2560Wh            |
| Charge Voltage                          | 14.2V             |
| Discharge Cut-Off Voltage               | 11.2V             |
| Standard Charge Current                 | 100 Amps          |
| Maximum Charge Current                  | 200 Amps          |
| Maximum Discharge Current               | 200 Amps          |
| Peak Discharge Current                  | 300 Amps (10mins) |
| Operating Temperature                   | -20°C - 60°C      |
| Maximum Number of Batteries In Parallel | 4                 |
| Number Of Discharge Cycles              | 3000              |
| Weight                                  | 22Kg              |
| IP Rating                               | IP20              |

## LB400-HD

### 12V HIGH DISCHARGE 400AH LITHIUM BATTERY

The LB400-HD boasts an astonishing 400Ah capacity and a market leading 300A discharge capability making it ideal to partner with high current drawing appliances such as 3000W inverters.



|   |                   |
|---|-------------------|
| PART No.                                | <b>LB400-HD</b>   |
| Nominal Voltage                         | 12.8V             |
| Nominal Capacity                        | 400ah             |
| Nominal Energy                          | 2560Wh            |
| Charge Voltage                          | 14.2V             |
| Discharge Cut-Off Voltage               | 11.2V             |
| Standard Charge Current                 | 100 Amps          |
| Maximum Charge Current                  | 200 Amps          |
| Maximum Discharge Current               | 200 Amps          |
| Peak Discharge Current                  | 300 Amps (10mins) |
| Operating Temperature                   | -20°C - 60°C      |
| Maximum Number of Batteries In Parallel | 4                 |
| Number Of Discharge Cycles              | 3000              |
| Weight                                  | 22Kg              |
| IP Rating                               | IP20              |

## INVCHR2

### 2000W 12V INVERTER/CHARGER

Perfect for powering the most demanding 240V appliances on the go this inverter/charger is ideal for operating on or off the grid. An RCD is included to ensure maximum safety for the unit and operator.

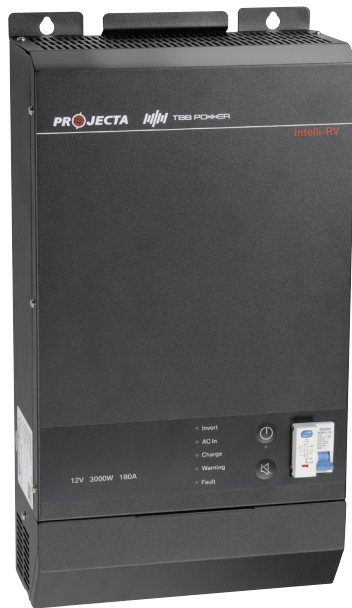

| PART NO.                 | INVCHR2                                   |
|--------------------------|---|
| 240V Charging            |   |
| Charge Type              | 5 Stage Automatic                         |
| Input                    | 240VAC, 50/60Hz, 32A(max)                 |
| Output                   | 12V, 120A                                 |
| Batteries Supported      | GEL, AGM, Wet, Lithium                    |
| Temperature Compensation | Yes                                       |
| INVERTER                 |   |
| Input                    | 12V (10.5~17V)                            |
| Output                   | 220 / 230 / 240 VAC                       |
| Frequency                | 50/60 Hz                                  |
| Output Power             | 2000W (4000W Peak)                        |
| Grid Boost Output        | 24Amps, (Mains supply + 8.3Amps inverter) |
| Ac Transfer              | <2mSec                                    |
| Operating Temperature    | -20 ~ 65°C                                |
| Weight                   | 17Kg                                      |
| IP Rating                | IP20                                      |
| Approvals                | EMC, AS/NZS 60335.2.29                    |

## INVCHR3

### 3000W 12V INVERTER/CHARGER

This 3000W Inverter/Charger is ideal for serious power hungry consumers who require lots of power for all their creature comforts on the road. An RCD (INVCHR3 only) is included to ensure maximum safety for the unit and operator.

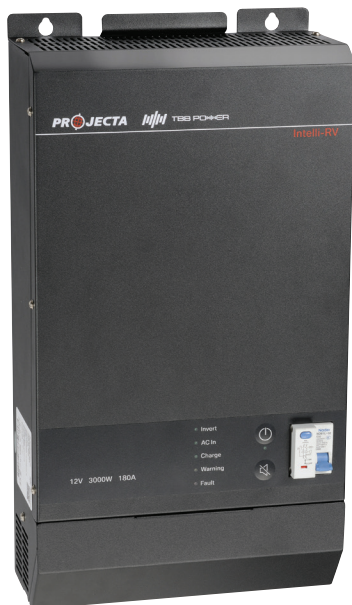

| PART NO.                 | INVCHR3                                    |
|--------------------------|--|
| 240V Charging            |  |
| Charge Type              | 5 Stage Automatic                          |
| Input                    | 240VAC, 50/60Hz, 32A(max)                  |
| Output                   | 12V, 180A                                  |
| Batteries Supported      | GEL, AGM, Wet, Lithium                     |
| Temperature Compensation | Yes  |
| INVERTER                 |  |
| Input                    | 12V (10.5~17V)                             |
| Output                   | 220 / 230 / 240 VAC                        |
| Frequency                | 50/60 Hz                                   |
| Output Power             | 3000W (6000W Peak)                         |
| Grid Boost Output        | 28Amps, (Mains supply + 12.5Amps inverter) |
| AC TRANSFER              |  |
|                          | <2mSec                                     |
| Operating Temperature    | -20 ~ 65°C                                 |
| Weight                   | 21Kg                                       |
| IP Rating                | IP20                                       |
| Approvals                | EMC, AS/NZS 60335.2.29                     |

# PM535J WIRING DIAGRAM WITH ADD-ON ACCESSORIES

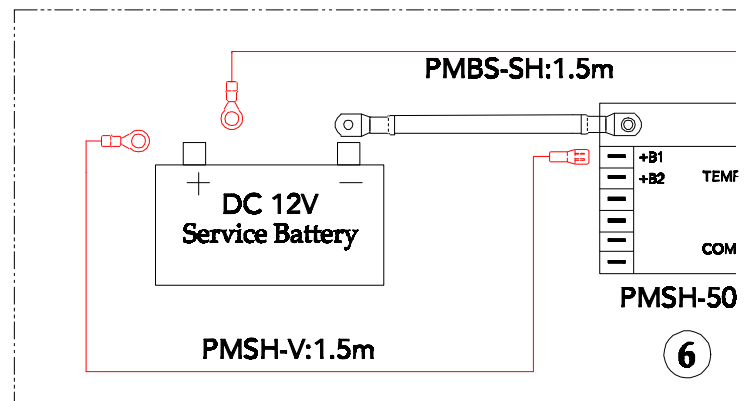
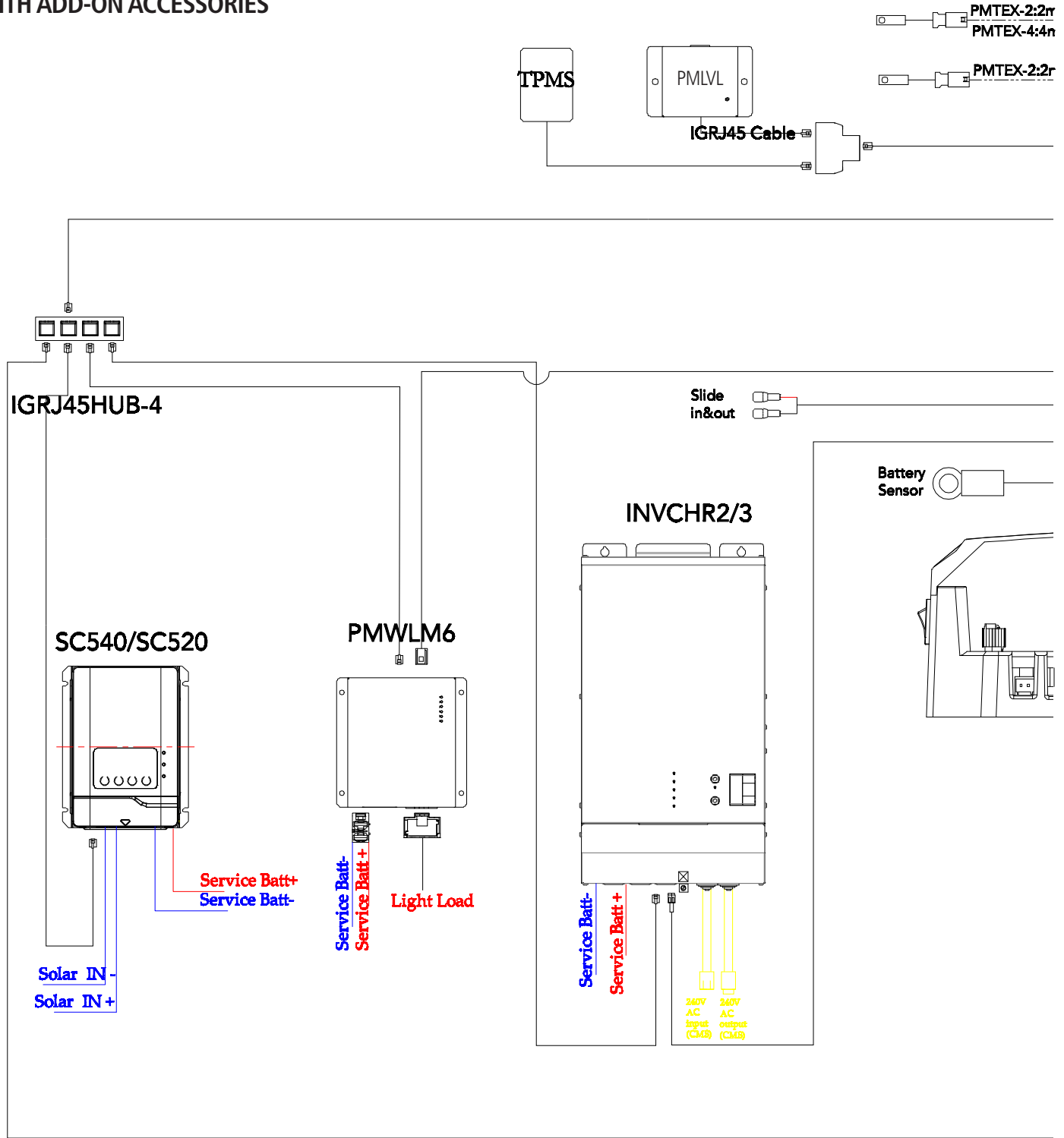

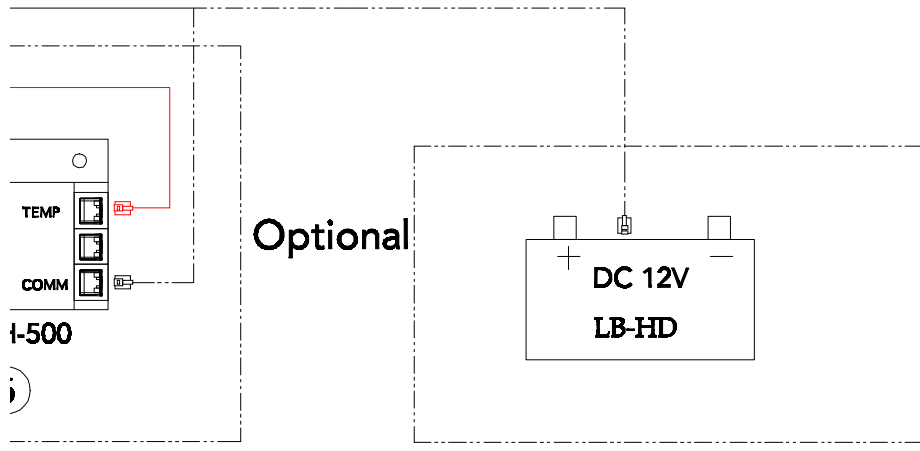
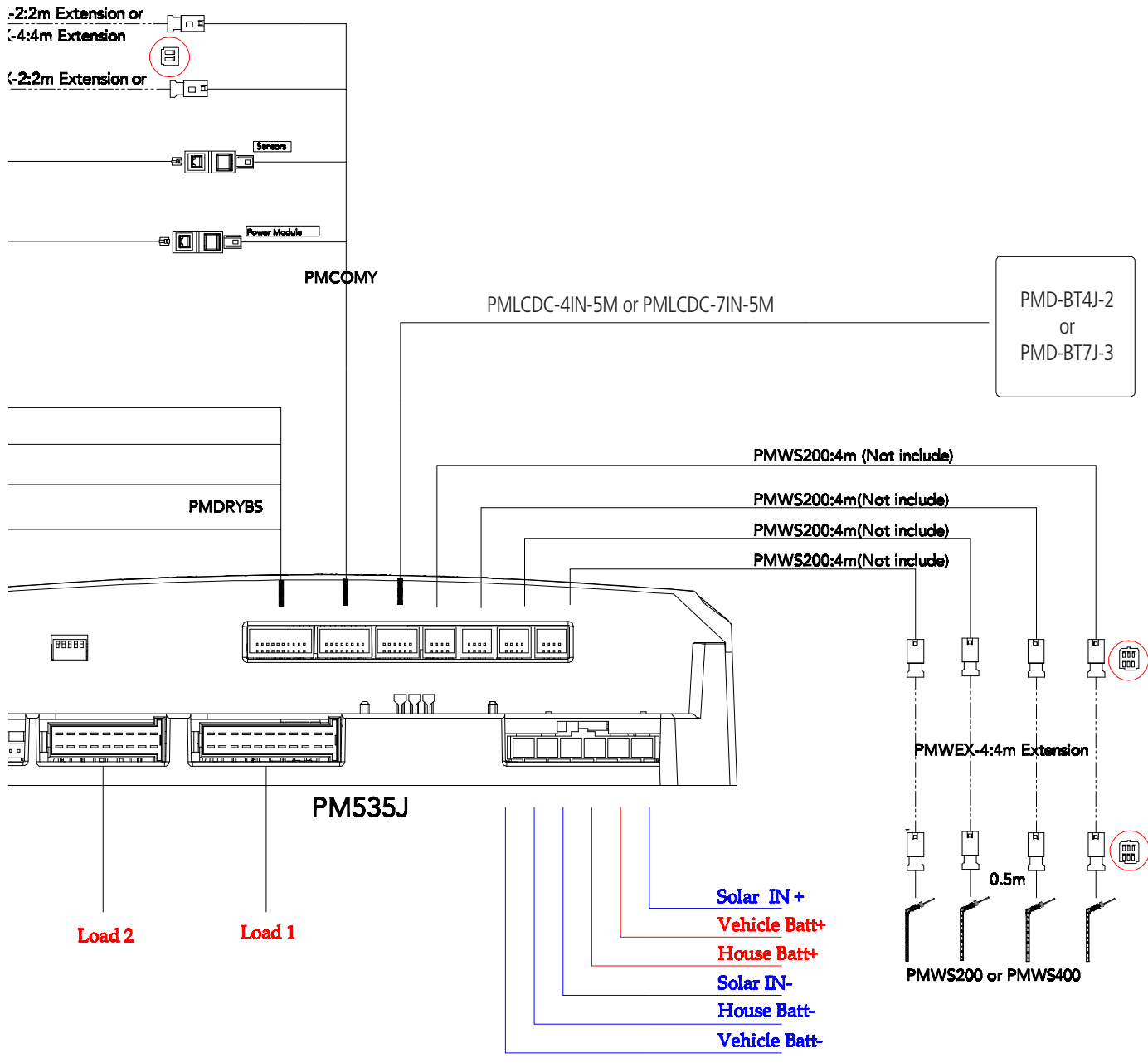

# WARRANTY STATEMENT

## Applicable only to product sold in Australia

Brown & Watson International Pty Ltd of 1500 Ferntree Gully Road, Knoxfield, Vic., telephone (03) 9730 6000, fax (03) 9730 6050, warrants that all products described in its current catalogue (save and except for all bulbs and lenses whether made of glass or some other substance) will under normal use and service be free of failures in material and workmanship for a period of 5 years (unless this period has been extended as indicated elsewhere) from the date of the original purchase by the consumer as marked on the invoice. This warranty does not cover ordinary wear and tear, abuse, alteration of products or damage caused by the consumer.

To make a warranty claim the consumer must deliver the product at their cost to the original place of purchase or to any other place which may be nominated by either BWI or the retailer from where the product was bought in order that a warranty assessment may be performed. The consumer must also deliver the original invoice evidencing the date and place of purchase together with an explanation in writing as to the nature of the claim.

In the event that the claim is determined to be for a minor failure of the product then BWI reserves the right to repair or replace it at its discretion. In the event that a major failure is determined the consumer will be entitled to a replacement or a refund as well as compensation for any other reasonably foreseeable loss or damage. This warranty is in addition to any other rights or remedies that the consumer may have under State or Federal legislation.

## IMPORTANT NOTE

Our goods come with guarantees that cannot be excluded under the Australian Consumer Law. You are entitled to a replacement or refund for a major failure and compensation for any other reasonably foreseeable loss or damage. You are also entitled to have the goods repaired or replaced if the goods fail to be of acceptable quality and the failure does not amount to a major failure.

### Distributed by

#### AUSTRALIA

**Brown & Watson International Pty. Ltd.**

Knoxfield Victoria 3180

Phone: (03) 9730 6000

Fax: (03) 9730 6050

National Toll Free: 1800 113 443

#### NEW ZEALAND OFFICE

**Brown & Watson International NZ Ltd.**

Mount Wellington, Auckland 1060

Phone: (09) 525 4575

IS632

Issue 1 20/10/24