

INTELLI Jay[®]

12V POWER MANAGEMENT SYSTEM

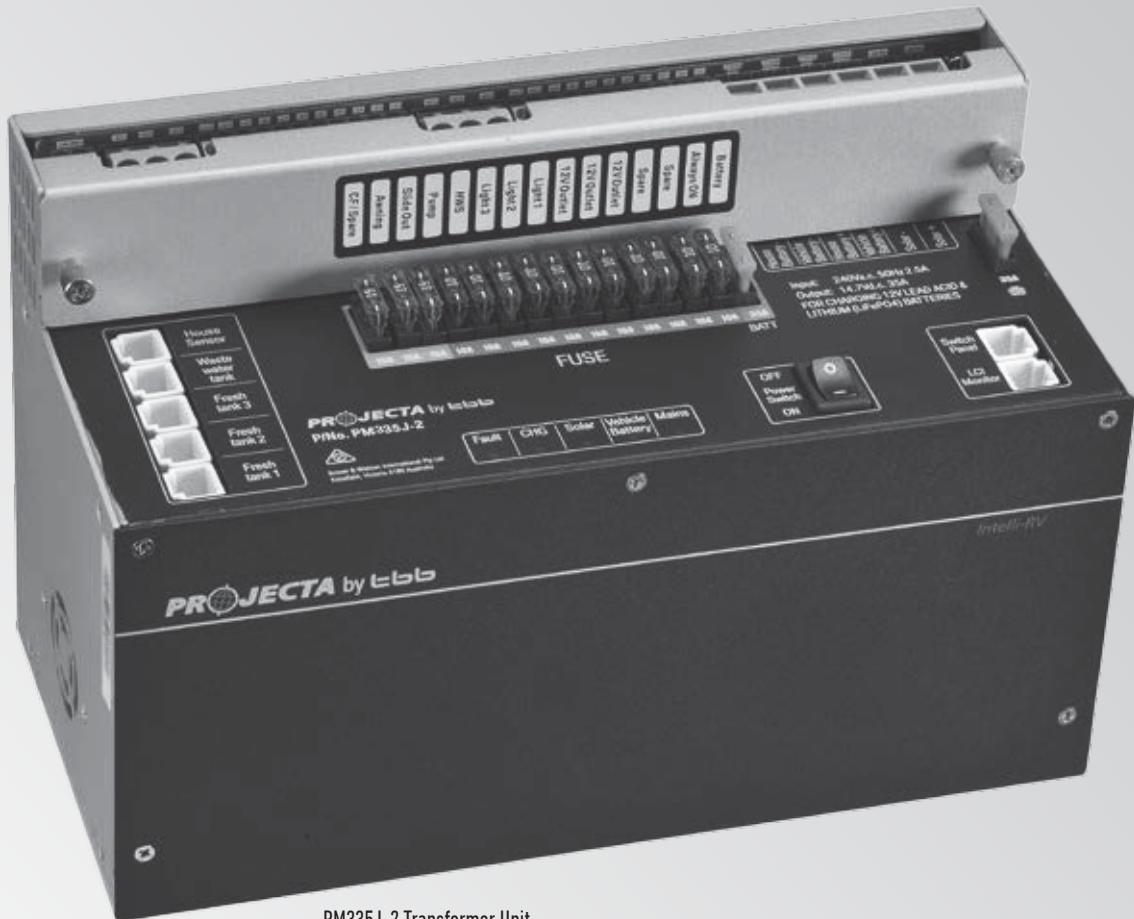

PM335J-2 Transformer Unit



PMD-BT4J Monitor

P/No. PM310-BT4J

Need technical help?
Contact Projecta on 1800 294 294

IMPORTANT SAFETY INFORMATION

Please read this manual thoroughly before use and store in a safe place for future reference.

WARNINGS

- Explosive gases. Prevent flames and sparks. Provide adequate ventilation during charging
- Before charging, read the instructions
- For indoor use. **Do not** expose to rain
- For charging Lead Acid and LiFePO₄ batteries **only** (of the size & voltage specified in the specification table)
- Always charge the battery on the correct voltage setting. Never set the charger to a higher voltage than the battery specification
- Disconnect the 240V mains supply before making or breaking the connections to the battery
- The battery charger must be plugged into an earthed socket outlet
- Connection to supply mains is to be in accordance with national wiring rules
- Do not attempt to charge non-rechargeable batteries
- Never charge a frozen battery
- If the AC cord is damaged, do not attempt to use. It must be replaced or repaired by a qualified technician
- Corrosive substances may escape from the battery during charging and damage delicate surfaces. Store and charge in a suitable area
- This charger is not intended for use by persons (including children) with reduced physical, sensory or mental capabilities, or lack of experience and knowledge, unless they have been given supervision or instruction concerning the use of the appliance by a person responsible for their safety
- Young children should be supervised to ensure that they do not play with the appliance
- If the recreational vehicle is to be put in to storage without power, please turn off the POWER SWITCH. If the recreational vehicle is to be put in to long term storage without power, disconnect ALL cabling from the battery.

CONTENTS

1. INTRODUCTION	4
1.1 Features	5
1.2 PMD-BT4J Touch Monitor (PM335J-2 only)	6
1.3 Water tank probes	6
2. KEY FEATURES AND FUNCTIONS	6
2.1 Multiple inputs	6
2.2 Battery charger of stationery/service battery	6
2.3 Power supply mode	7
2.4 MPPT solar charger controller	7
2.5 Voltage charging relay (VCR)	7
2.6 Categorised outputs	8
2.7 Battery low voltage protection	8
2.8 Manual battery switch	8
2.9 Silent mode	8
3. STRUCTURE AND INSTALLATION	9
3.1 PM335J-2 Transformer Unit	9
3.3 Water tank probes	11
3.3.1 PMWS400 water tank probe	11
3.3.2 PMWS200 water tank probe	11
4. WIRING	12
4.1 Material	12
4.2 System schematic	12
4.3 Preparation	14
4.4 Connection	14
5. DISPLAY	15
5.1 PM335J-2 Transformer Unit	15
5.2 PMD-BT4J Touch Monitor	16
5.2.1 PMD-BT4J Touch Monitor Switch Explanation	16
6. OPERATION	17
6.1 Configuration on PM335J-2 Transformer Unit	17
6.1.1 Load Remote Isolation Switch	17
6.2 Connecting to a Smart Device (Bluetooth)	17
6.3 Using the PM335J-2 Remote App	17
6.4 Maintenance	18
6.4.1 Battery monitoring maintenance	18
6.4.2 Daily maintenance	18
7. TROUBLE SHOOTING	18
7.1 PMD-BT4J Display on PM335J-2 Unit	18
7.2 Solving an 8032 Over Voltage Outage with the PM335J-2 Remote App	19
8. ADD-ON ACCESSORIES	20
8.1 PM335J-2 Accessory Range	20
8.2 Connecting & using Projecta add-on accessories	23
9. SPECIFICATION	27

1. INTRODUCTION

PM310-BT4J system is a power management system designed for use in caravans or motor homes. These systems allow for easy installation and a user-friendly interface.

PM310-BT4J system uses the PM335J-2 Transformer Unit, to which the circuits in the caravan or motor home are centrally wired. This transformer features built-in battery charger, power supply, fused distribution blocks, MPPT solar charge controller, voltage charging relay (VSR), low voltage disconnect (LVD), water pump controller, hot water system controller, water tank indicator and battery monitoring.

SYSTEM COMPONENTS:

1. PM335J-2 Transformer Unit
2. PMD-BT4J Monitor
3. Cables (Refer to Chapter 4 for the cable list)

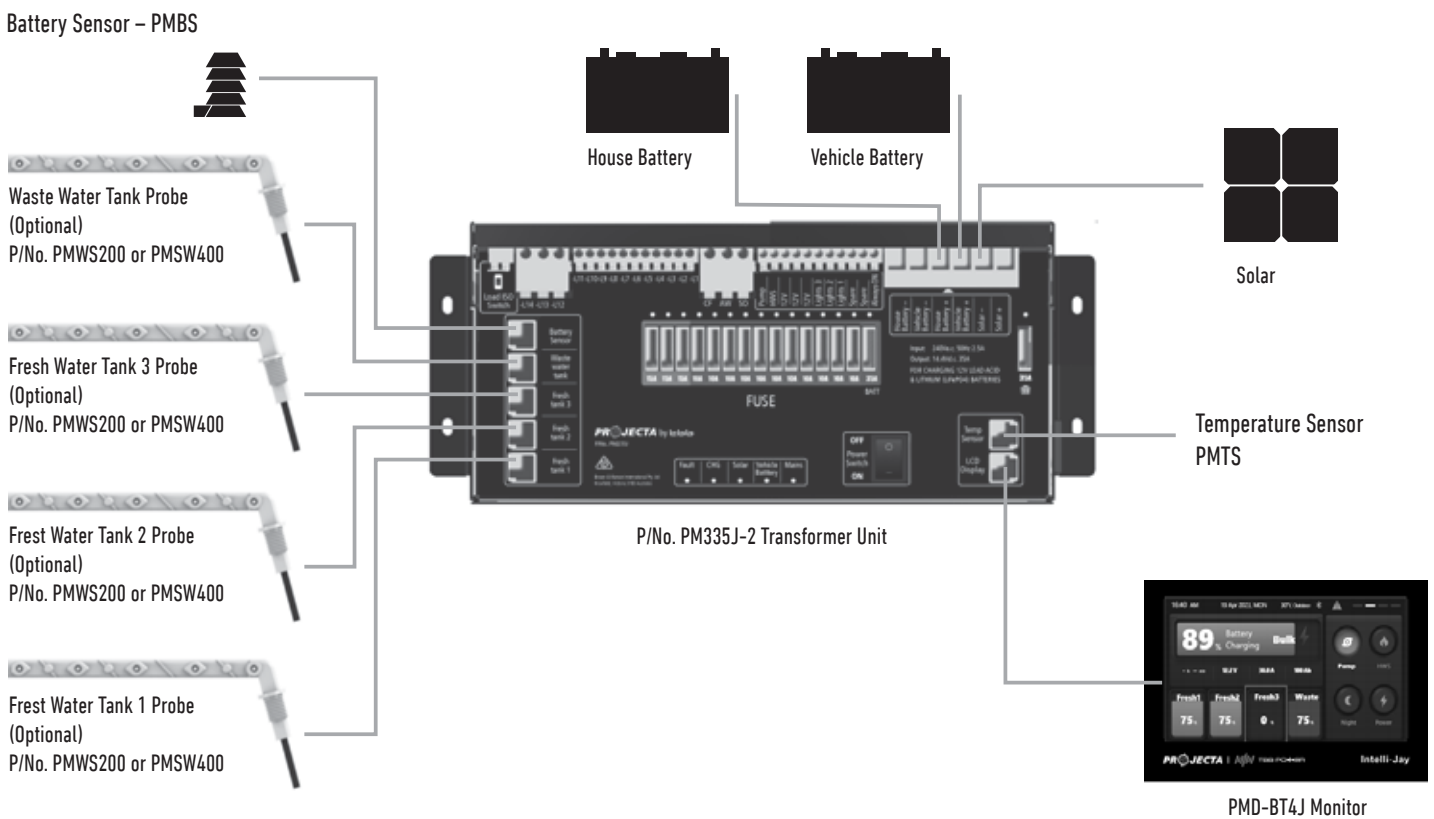

Figure 1 System Components for PM310-BT4J

1.1 Features

- Smart battery charger 12V35A(30A for charging current)
- Multistage adaptive charging algorithm
- Active Power Factor Correction (PFC) charging
- Temperature compensation charging
- Voltage compensaton charging
- Solar charge controller (MPPT), 30A
- 14 built in fused outputs
- Low battery voltage protection
- Builtin battery switch to isolate the battery when in storage
- Built-in shunt for precise battery measurement
- 1 water pump control with up to 4 connections for water sensors
- Thermal control fan
- Spring terminal and screw terminal
- T-bus compatible
- 12V Alternator Charging
 - 60A Continuous
 - 100A for 30mins

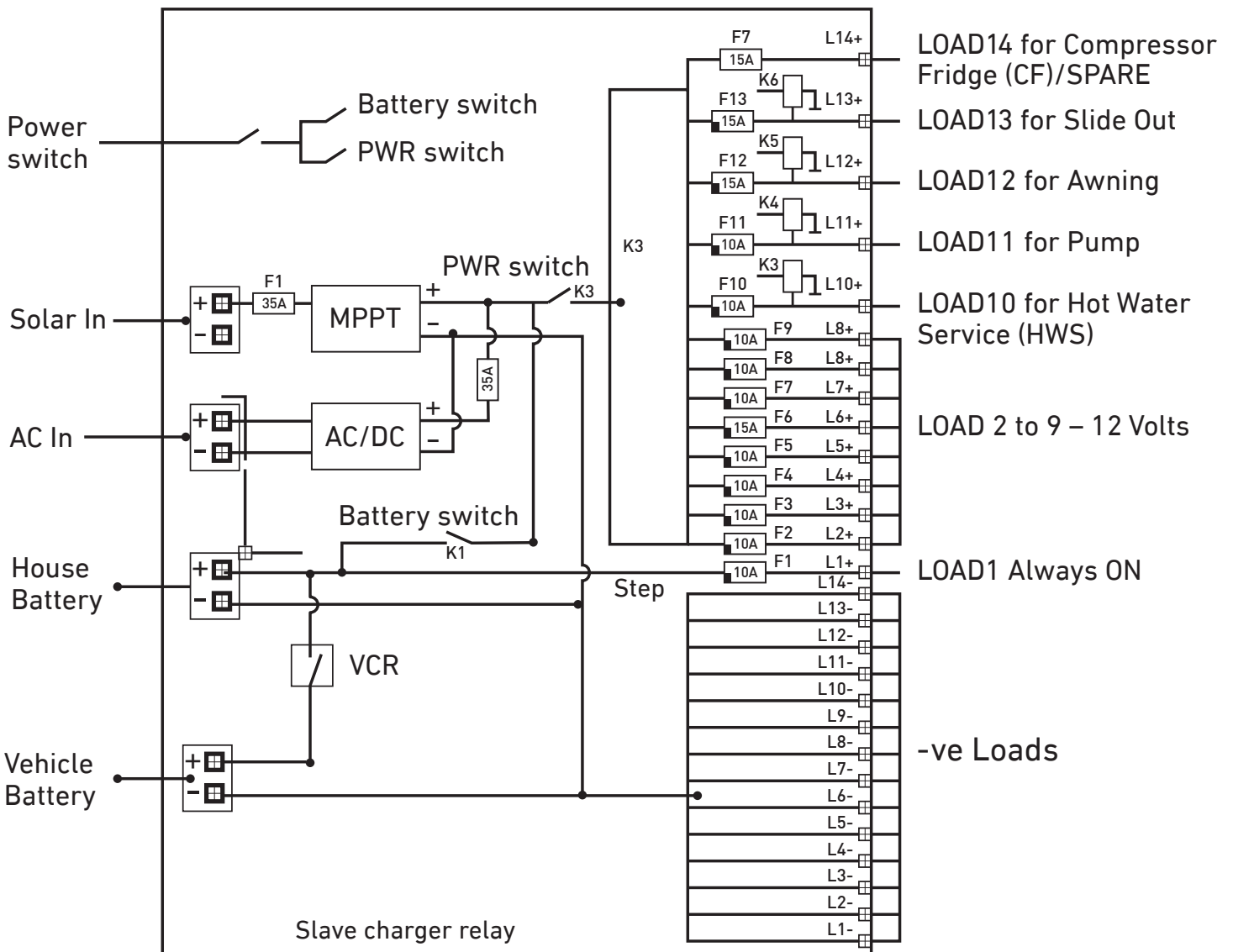

Figure 2 System Schematic

1.2 PMD-BT4J Touch Monitor

The PMD-BT4J Touch Monitor is a digital control center for the PM335J-2 transformer unit. See section 5.2 for operation of PMD-BT4J Touch Monitor.

FEATURES:

- T-Bus design (can be connected to multiple devices)
- System monitoring
- Configuration
- Built-in Bluetooth for pairing to smart phone

For technical assistance on PMD-BT4J Touch Monitor, please contact your Jayco Dealership.



Figure 3 Overview of Monitor

1.3 Water Tank Probes

A maximum of up to 4 probes can be monitored by the system.

NOTE: Always check the probe required for the water tank before purchase.

There are 2 probe styles:

PMWS200:

- Side installation
- Suitable for water tank
- Depth >200mm

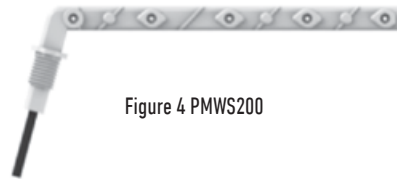

Figure 4 PMWS200

PMWS400:

- Side installation
- Suitable for water tank
- Depth 300-400mm

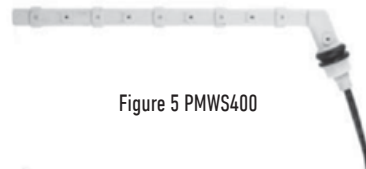

Figure 5 PMWS400

2. KEY FEATURES AND FUNCTIONS

2.1 Multiple Inputs

The PM335J-2 transformer unit accepts inputs from AC mains, solar panel and vehicle battery. However, see Table 1 at right for details.

AC MAINS	X	X	
SOLAR	X		X
VEHICLE BATTERY		X	X
DOMINATING SOURCE	AC MAINS	AC MAINS	COMBINE

Table 1 Multiple inputs

2.2 Battery Charger of House Battery

The charger automatically starts when the appropriate qualified power is connected, either from AC mains, alternator or solar.

With multiple charging stages (soft start-bulk absorption float-recycle), PM335J-2 is designed to fully charge a battery quickly. To guarantee the optimal charging for batteries of different states, the PM335J-2 features a Microprocessor-controlled charging algorithm. The Float and Recycle charging programs guarantees that the battery condition does not change despite being connected for a longer period.

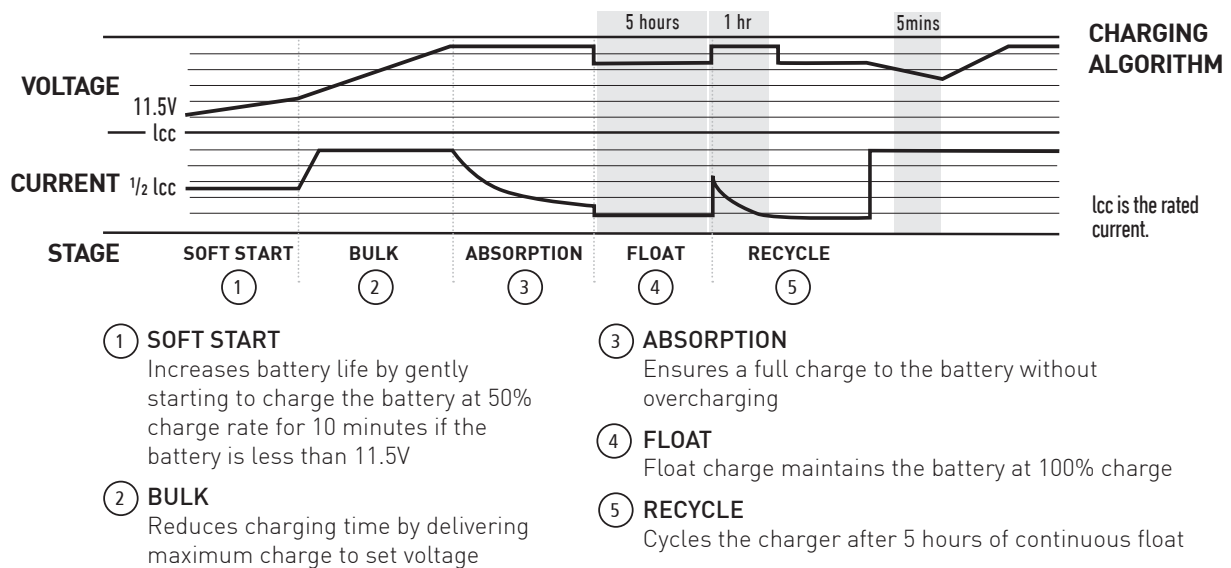

Figure 6 Charging Algorithm

Battery Temperature Sensor

The PMBS (battery sensor cable) is connected to measure the temperature of the battery and automatically adjusts, in real time, to charge the battery properly at compensation rate of $-4\text{mv} \pm 10\% / ^\circ\text{C} / \text{cell}$. In case PMBS is not present, the PM335J-2 will use 25°C as default.

Voltage Compensation Charging

With a voltage sensor the PM335J-2 can automatically adjust its output to compensate the voltage drop caused by a cable. This assures the right voltage is being delivered for optimal charging.

Adjustable Charging Capacity

Users can adjust the charging current by specifying the battery capacity. The charging current is set at threshold rate of 15% the of the battery capacity ($I = 0.15C$) by default.

Lithium Battery Charging

The PM335J-2 can be configured to charge a lithium battery. With a lithium battery, the max charging current will automatically be set at 30% of battery capacity ($I_{\text{max}} = 0.3C$).

2.3 Power Supply Mode

If no battery is attached to PM335J-2 unit, it will work as a power supply automatically with a 12.8VDC output.

2.4 MPPT Solar Charger Controller

PM335J-2 has a built-in MPPT charger for the service battery.

- Max input voltage 50VDC
- Max charging current 30A
- Max supply current 30A

2.5 Voltage Charging Relay (VCR or commonly known as a VSR)

As a Safety feature, the Slide Out Ext/Ret function is disabled by the PMD-BT4J Touch Monitor when towing vehicle is connected to the Caravan (and vehicle battery voltage is detected at $>5\text{V}$). To enable these outputs again, disconnect the vehicle's power plug from the caravan. If the VCR is still engaged, press the PWR button on the PMD-BT4J Touch Monitor or app ON / OFF / ON.

LEAD ACID BATTERY – When the start battery reaches 13.4VDC with threshold time delay, the VCR will charge the house battery from the alternator. VCR will continue charging until the starter battery voltage drops under 12.8VDC.

LiFePO₄ LITHIUM BATTERY – When the starter battery reaches 13.7VDC with threshold time delay, the VCR will charge the house battery from the alternator. The VCR will continue charging until the starter battery voltage drops below 13.3VDC with less than 2A charge to the service battery with threshold time delay.

NOTE: The PM335J-2, when charging from the starter battery, does not provide 5 stage charging. It simply takes whatever power and charging is available from the alternator.

NOTE: If your vehicle is fitted with a smart alternator, the VCR charge system (Variable Voltage or Temperature Compensating), the VCR charge system may not function correctly and a Projecta DCDC Charging system is recommended.

Please contact Projecta for further information.

2.6 Categoricalised Outputs

The 14 outputs are categorised into groups and controls as per below:

OUTPUTS	DESCRIPTION	POSSIBLE LOAD SUITABLE
4	Relay controlled output with fuse, protected by main master switch relay	Awning, Slide Out, Hot Water System (HWS), Pump
9	Fused outputs, protected by master switch relay	Lights, ventilation fan, TV etc.
1	Always ON	Auto step, radio/clock memory etc.

Table 2 Categoricalised outputs

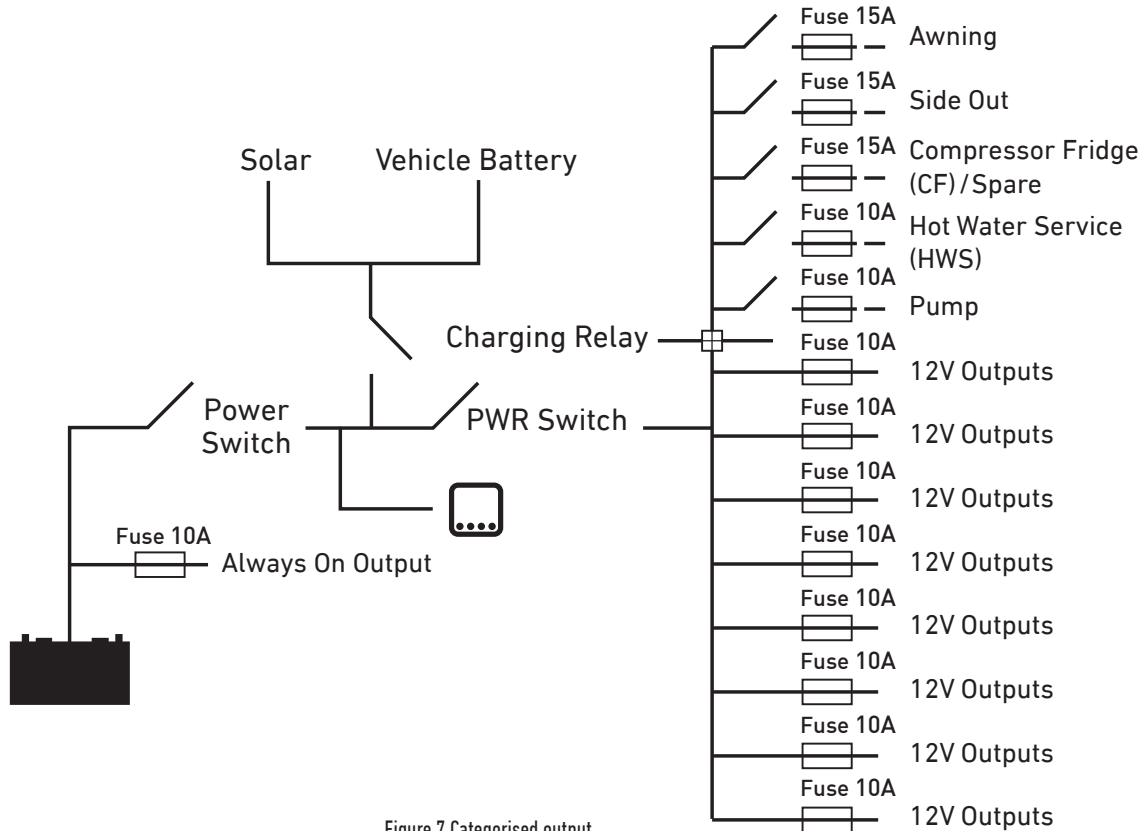

Figure 7 Categoricalised output

2.7 Battery Low Voltage Protection (BLVP or commonly known as an LVD)

The PM335J-2 transformer unit has a built-in low voltage protection relay. It will disconnect the load once the battery voltage drops below the threshold voltage. The default setting is 10.5VDC.

2.8 Power Switch

The PM335J-2 transformer unit offers a convenient way to cut off charger and switch off the outputs of the House Battery. It protects the House Battery from being drained by the on board electronics, completely isolating the battery, perfect for storage. This switch is located on the front face of the PM335J-2 transformer unit.

2.9 Precise Battery Measurement

The PM335J-2 transformer unit has a battery measurement system controlled by microprocessor. It measures battery voltage, charge/discharge current, remaining Amp-hours and display time to go.

Compared to conventional indicating meters, a small current can be measured and read accurately with this device. With this feature, it highlights faults, alarms and installation errors.

NOTE: If you have loads connected directly to the battery instead of through the PM335J-2 transformer unit, the measurement will not be accurate.

3. STRUCTURE AND INSTALLATION

3.1 PM310-BT4J Power Management System

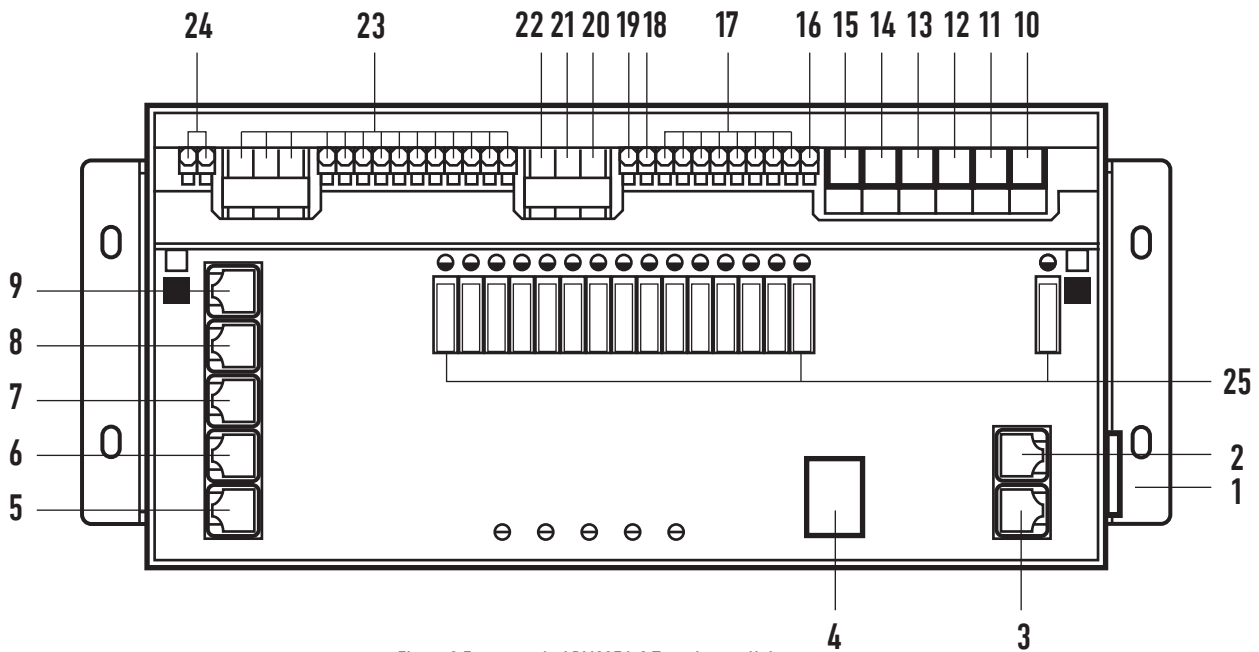

Figure 8 Front panel of PM335J-2 Transformer Unit

Nº	LABEL	DEFINITION	DESCRIPTION
1	AC Mains	AC input port	Computer/IEC style plug socket
2	Temp Sensor	Comm port	Temperature Sensor input
3	PMD-BT4J Monitor	Comm port	Connect to Monitor
4	Power switch	Charger and house battery switch	Manual battery switch
5	Fresh water tank 1		Connect to fresh water tank 1
6	Fresh water tank 2		Connect to fresh water tank 2
7	Tap water tank 3		Connect to tap water tank
8	Waste water tank 4		Connect to waste water tank
9	House Sensor	For temp compensation	Connect to house battery
10	Solar+	Solar input	Connect to solar panel + terminal
11	Solar-	Solar input	Connect to solar panel - terminal
12	Vehicle Bat+	Vehicle battery+	Connect to vehicle battery+ (<20Vdc)
13	House Bat+	House battery+	Connect to house battery+ (<20Vdc)
14	Vehicle Bat-	Vehicle battery-	Connect to vehicle battery-
15	House Bat-	House battery-	Connect to house battery-
16	L1+	Always ON	Connect to permanent +12 Volts
17	L2+ ~ L9+		Connect to isolating +12 Volts
18	L10+	HWS (Hot Water System)	Connect to HWS+
19	L11+	Water pump	Connect to water pump+
20	L12+	Slide out	Connect to slide out+
21	L13+	Awning	Connect to awning+
22	L14+	Spare/CF (Fridge)	Connect to CF+
23	L1- ~ L14-		Connect to DC load-
24	Remote ISO Switch	Terminal block	Connect to external switch (optional)
25	Fuse		Fuse and fuse failure indication

Table 3 Categorized outputs

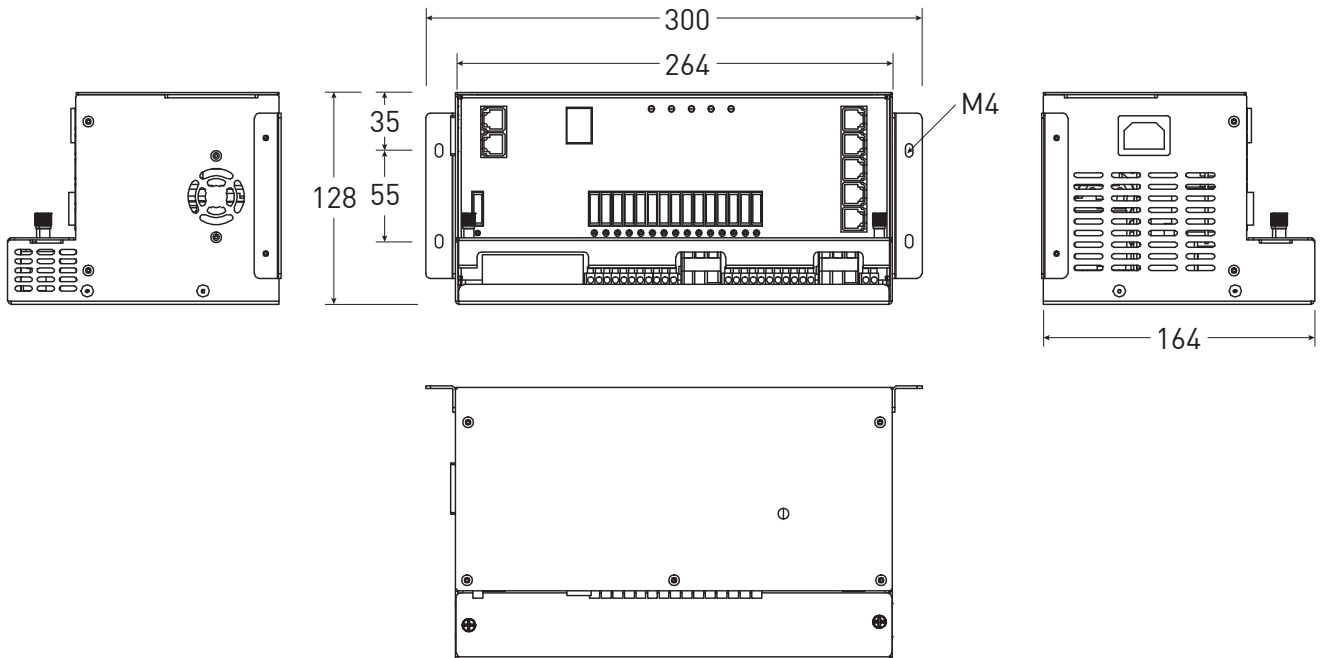

Figure 9 Dimension of PM335J-2 (Unit: mm)

Installation:

PM335J-2 can be installed on a horizontal surface or vertically on a wall. Please see following instructions:

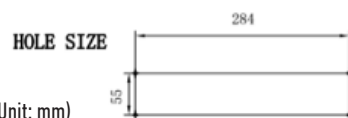
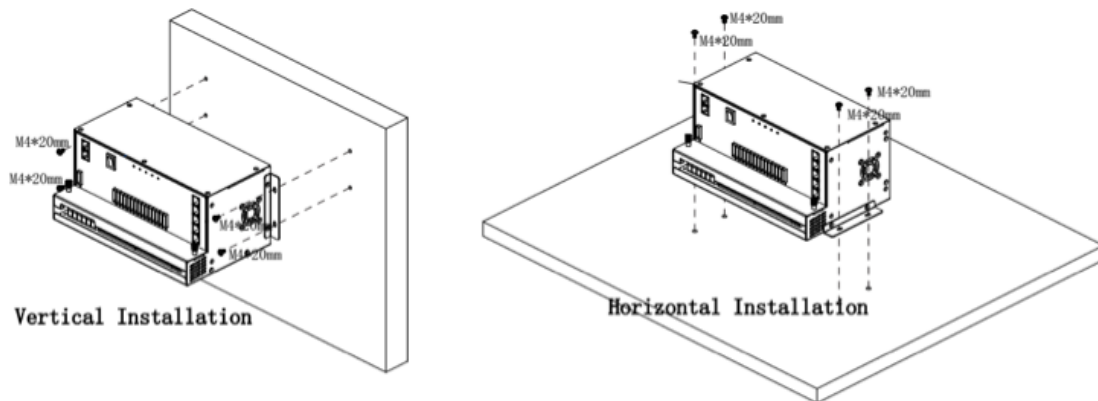

Figure 10 Installation of PM335J-2 (Unit: mm)



Ensure clearance on both sides of PM335J-2 unit upon installation. A recommended clearance of 5cm on each side.

3.2 Water Tank Probes

3.2.1 PMWS400 Water Tank Probe

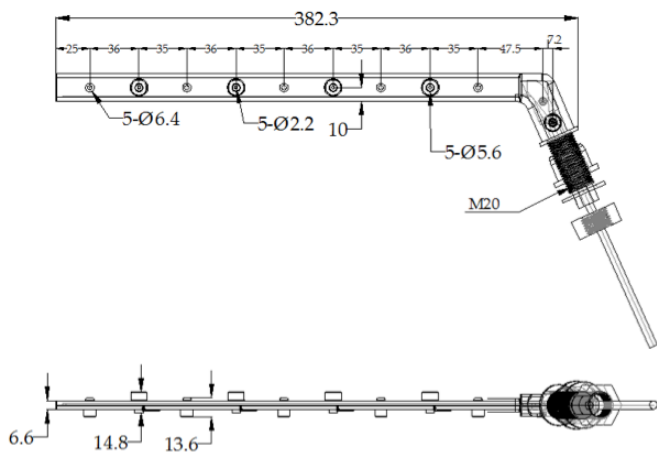

Figure 11 Dimension of PMWS400 (Unit:mm)

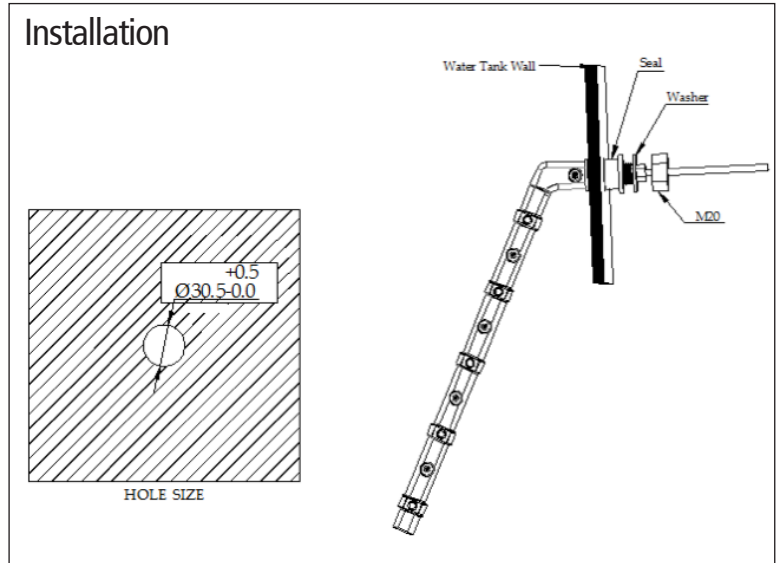

Figure 12 Installation of PMWS400

3.2.2 PMWS200 Water Tank Probe

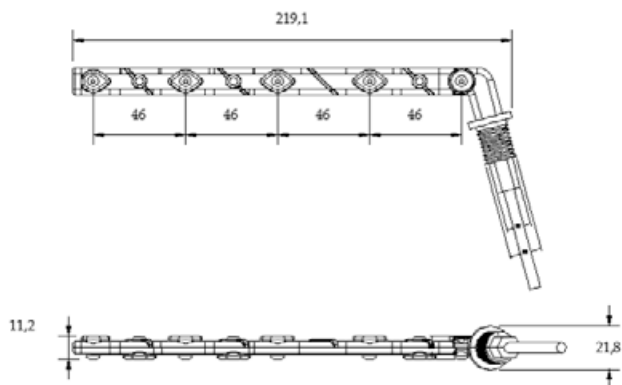

Figure 13 Dimension of PMWS200 (Unit:mm)

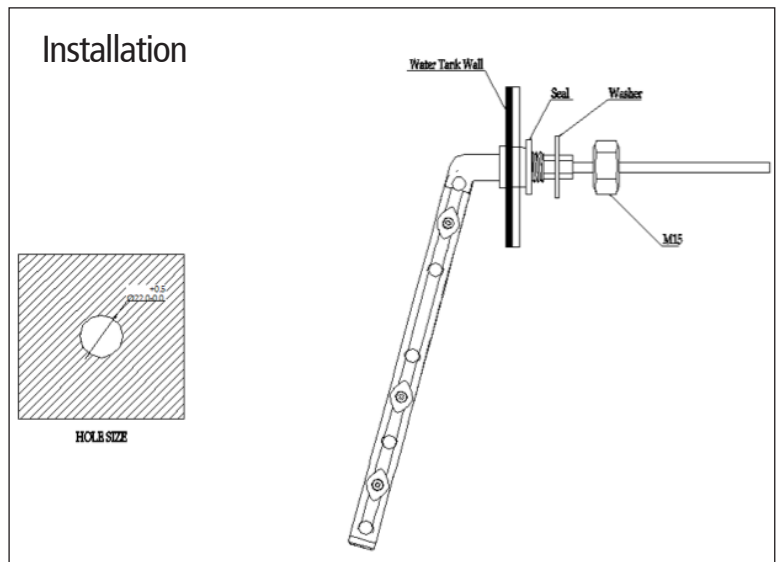
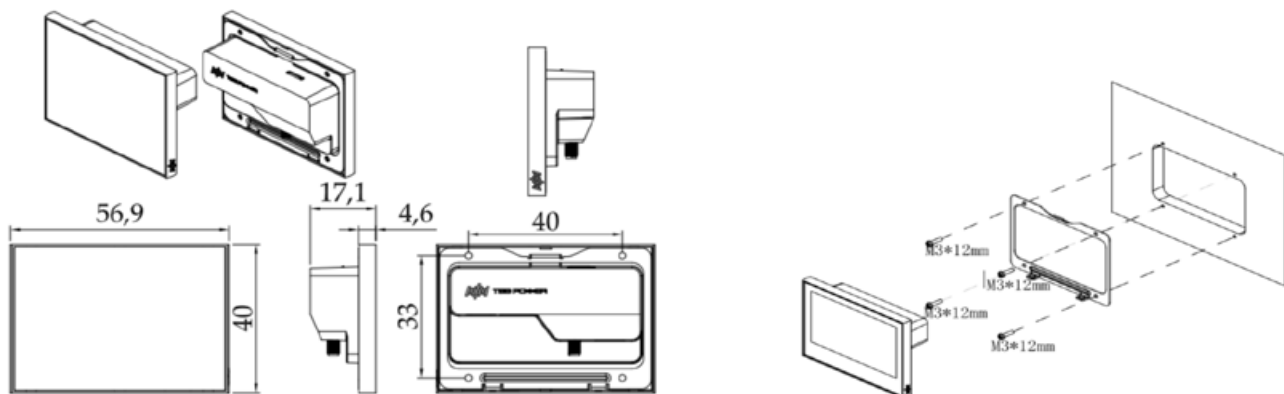

Figure 14 Installation of PMWS200

3.3 Monitor



4. WIRING

4.1 Material

CODE	NAME	MODEL/ LENGTH	QTY	P/No. ON DRAWING
1	Transformer Unit	PM335J-2	1	1
2	Touch Monitor	PMD-BT4J	1	2
3	Fresh water tank 1 level sensor	Not included and to be ordered separately	0	4
4	Fresh water tank 1 level sensor		0	5
5	Tap water tank level sensor		0	6
6	Waste water tank level sensor		0	7
7	Solar		0	9
10	Communication line (RS485)	10m	1	PMLCDC-10
11	Temperature line	5m	1	PMTS
12	Battery sensor line	3m	1	PMBS
13	Water tank probe line	Not included	0	PMWS200 / PMWS400
14	Water tank probe line		0	
15	Water tank probe line		0	
16	Water tank probe line		0	
17	Power Cable	1.5m	1	PMAC

Table 4 Component List of PM310-BT4J

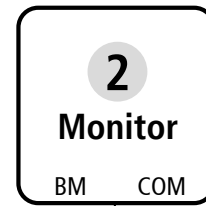

PMLCDC

AC in
240V / 50Hz
~

L
N

PMAC

House Battery
(12VDC)

House Battery -
House Battery +

Vehicle Battery
(12VDC)

Vehicle Battery -
Vehicle Battery +

Solar in
Vmp: 17-50V

Solar-
Solar+

9 Solar

4.2 System Schematic

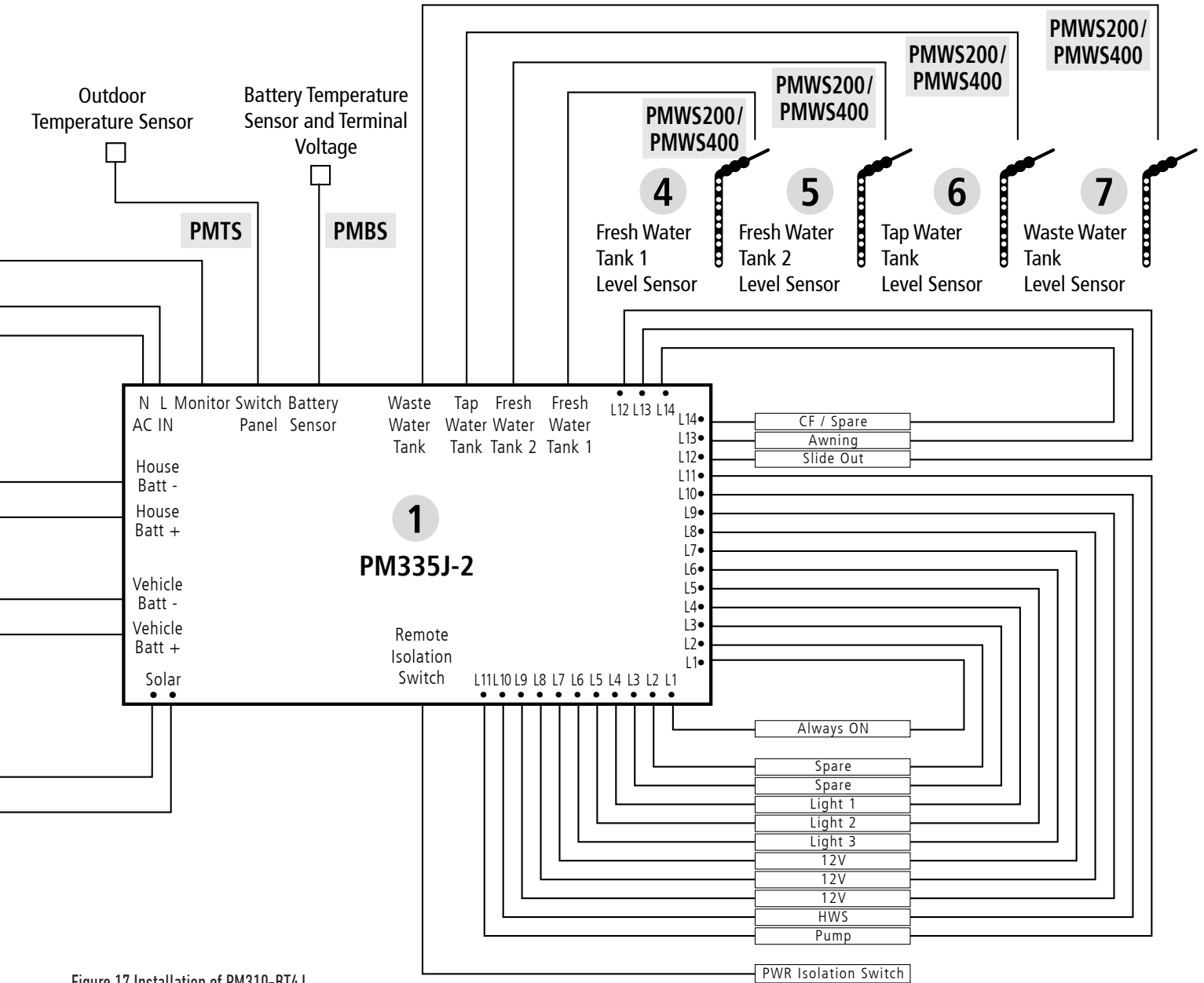

Figure 17 Installation of PM310-BT4J

4.3 Preparation

The PM310-BT4J system is designed with the concept of 'Plug in and Play' in mind. To complete the easy installation, a screw driver and DC cables are required. Follow Table 5 recommendation for minimum wiring size.

CURRENT	MINIMUM CABLE SIZE
0–5A	1.0mm ² or 18 AWG
5–10A	2.0mm ² or 14 AWG
10–15A	3.0mm ² or 13 AWG
15–20A	4.0mm ² or 11 AWG
20–25A	5.0mm ² or 10 AWG
25–30A	6.0mm ² or 9 AWG

Table 5 Minimum cable size



When running cables, if they pass through panels or wall, ensure the cables are protected from damage by sharp edges. In such cases, it is recommended to use cable glands.

4.4 Connection

PM335J-2 transformer unit is designed with a spring and screw terminal. Please refer to following illustration at right. Each type of terminal is designed to fit a different range of cables.

TYPE	TERMINAL MODEL NUMBER	SUITABLE CABLE GAUGE
Type 1	ERTB10-10.16	0.5mm ² – 10mm ²
Type 2	Wago804-114	0.25mm ² – 2.5mm ²
Type 3	Wago2704-103	0.5mm ² – 6mm ²

Table 6 Recommended terminal and cable gauge

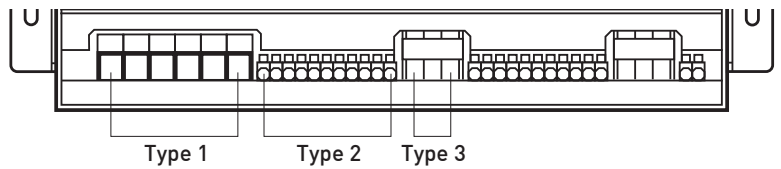

Figure 18 PM335J-2 Terminals

TYPE 1

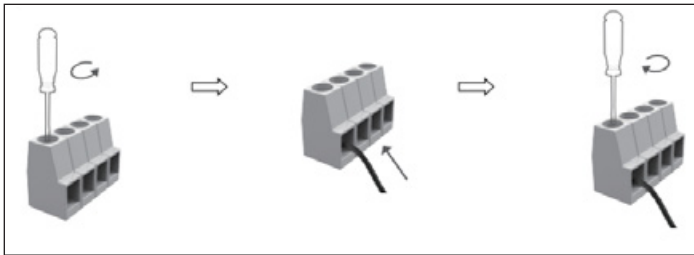

Figure 19 Connection of Terminal Type 1

TYPE 3

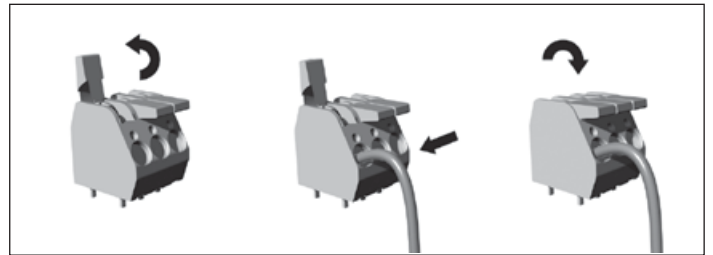

Figure 21 Connection of Terminal Type 3

TYPE 2

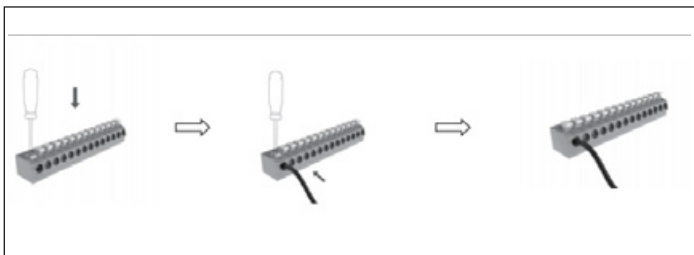

Figure 20 Connection of Terminal Type 2

5. DISPLAY

5.1 PM335J-2 Transformer Unit

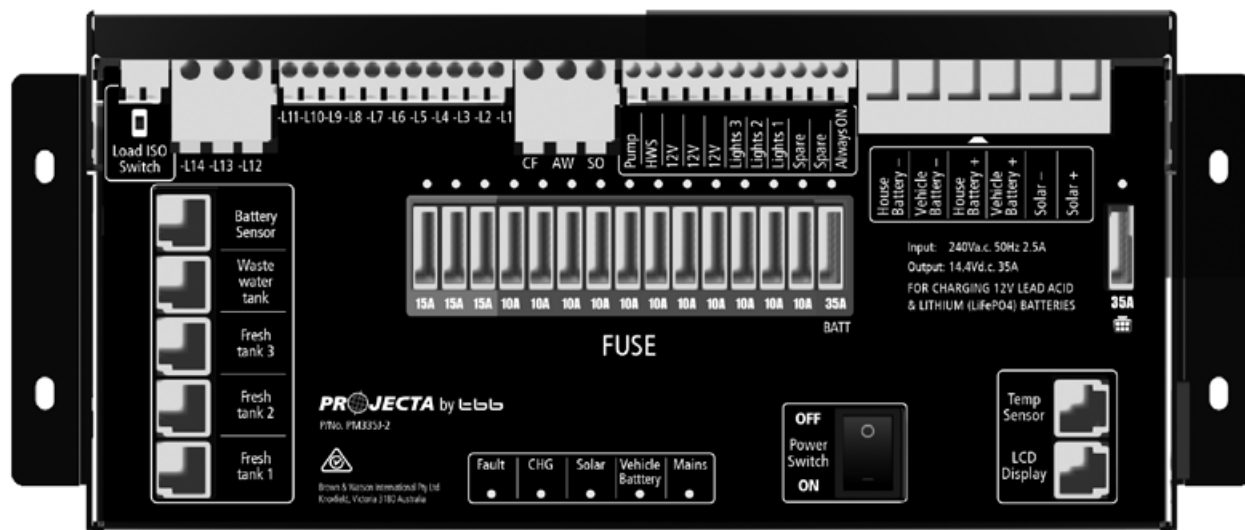

Figure 22 An overview of PM335J-2

No.	LED	COLOUR	STATUS	DESCRIPTION
1	Mains	GREEN	ON	AC input OK
			OFF	AC disconnected
			Quick flashing (flash twice every second)	AC input abnormal
2	Vehicle Bat	GREEN	ON	Alternator charging the house battery
			Slow flashing (flash once every second)	Vehicle battery is >13.4V and is being charged by the AC
			Quick flashing (flash twice every second)	The vehicle battery is 2~13.4V or >16.0V, while AC power is connected.
			OFF	Vehicle battery is disconnected.
3	Solar	GREEN	ON	Solar charging the battery
			Slow flashing (flash once every second)	The input voltage of the Solar is normal but it is charged by the AC or vehicle battery
			Quick flashing (flash twice every second)	Solar input voltage error – Solar voltage >50Vdc
			OFF	Solar disconnected
4	CHG	GREEN	ON	Battery charged
			Slow flashing (flash once every second)	Battery charging
			Quick flashing (flash twice every second)	Battery discharge
			OFF	Battery disconnected
5	FAULT	RED	ON	Short circuit
			Flash once per cycle	House battery voltage low
			Flash twice per cycle	House battery voltage high
			Flash 3 times per cycle	PM335J-2 unit Over Temperature
			Flash 4 times per cycle	Bulk charge timeout
			Flash 5 times per cycle	VCR anomaly
			Flash 6 times per cycle	Environment Over Temperature

Table 7 LED indicator description of PM335J-2

5.2 PMD-BT4J Touch Monitor

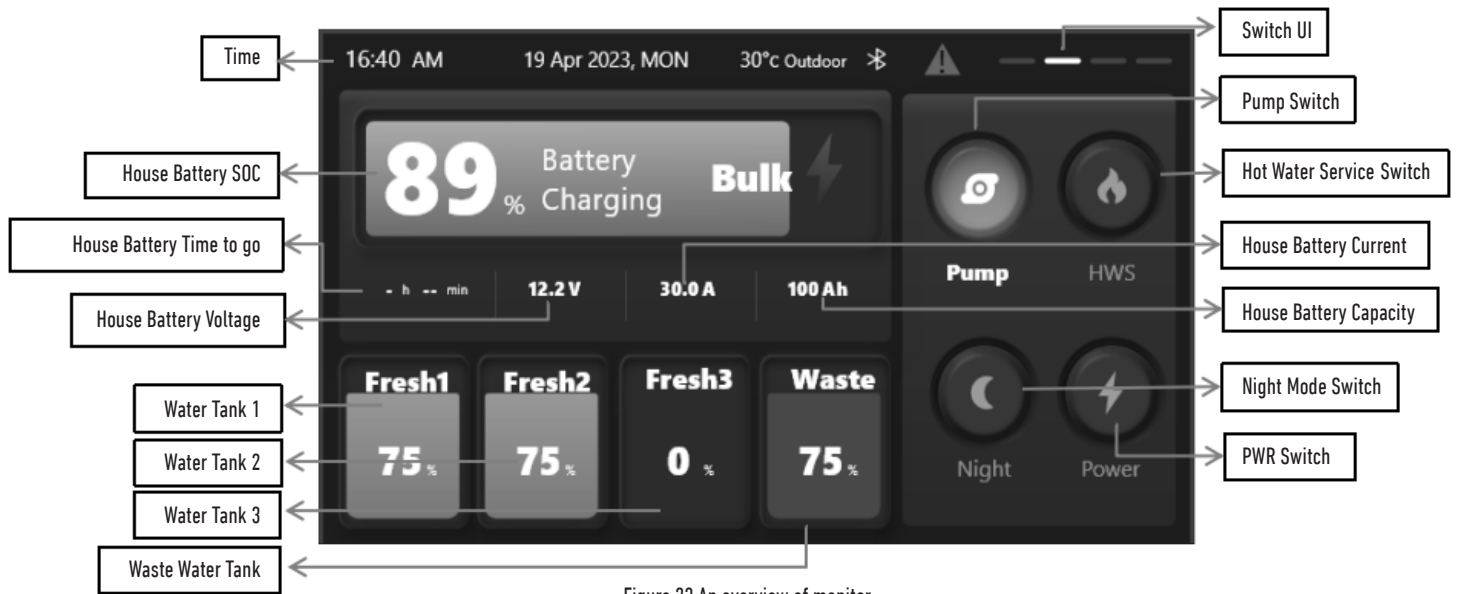

Figure 23 An overview of monitor

The monitor can be paired to a smart phone via the smart device app. This app will display the battery parameters, water tank levels, allow pump control and power isolation. Refer to section 6.3 for the Bluetooth pairing procedure.

5.2.1 PMD-BT4J Touch Monitor Switch Explanation

SWITCH	FUNCTION	DESCRIPTION
Power	To switch off all loads connected on DC charger	Refer Figure 24
Pump	To switch on/off Pump	Refer Figure 25
HWS	To switch on/off Hot Water Service	Refer Figure 26
Night	To switch on/off Night Mode	Refer Figure 27

Table 8 Switch Explanation

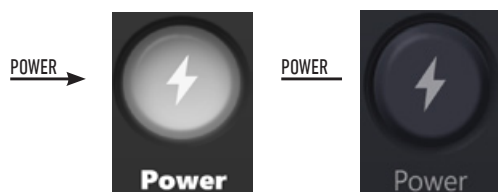

Figure 24 Switch ON /OFF all DC loads

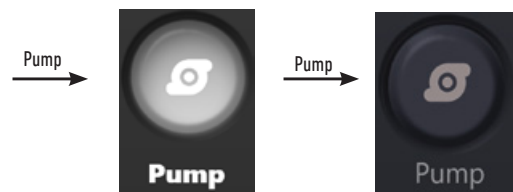

Figure 25 Switch ON /OFF Pump

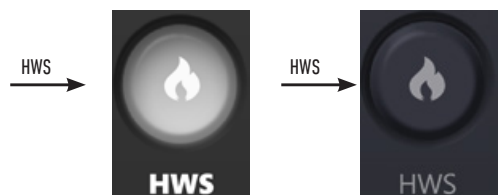

Figure 26 Switch ON /OFF Hot Water Service



Figure 27 Switch ON /OFF Night Mode

6. OPERATION

6.1 Configuration on PM335J-2

Configuration of the battery type and capacity can be done through the PMD-BT4J Touch Monitor or the smart device app.

6.1.1 Load Remote Isolation Switch

This function allows for the use of a remote ISO switch to turn ON/OFF the L2-L14 outputs.

6.2 Connecting to a Smart Device (Bluetooth)

1. Go to your smart device's App Store (iPhone/iPad) or Play Store (Android) and search for the Jayco "IntelliJay PM210&310" app. Download this app to your smart device.
2. Ensure Bluetooth is enabled on your smart device and that permission is granted for the app to use Bluetooth and discover new connections.
3. Open the app and it will begin searching for your PMD-BT4J Touch Monitor. When it shows up in the device list, tap and you will be prompted to enter a pairing code.
4. This pairing code will be displayed on the PMD-BT4J Touch Monitor/screen of PM310-BT4J Systems. Enter this code on your smart device and confirm.

If your system does not show up in the device list, ensure the following:

- You are within close enough proximity to the PMD-BT4J Touch Monitor
- The PMD-BT4J Touch Monitor or Bluetooth node is properly connected to the PM335J-2 transformer and is operational
- Your smart device operating system is up to date (iOS 8.0 and higher, or Android 4.4 and higher)

6.3 Using the PM335J-2 Remote App

1. Once you have established a paired connection with your smart device, the app will take you to its home screen where you may see a variety of system parameters.
2. It is now important to select your battery type, to ensure ideal charging and system operation. To do this, tap the white settings cog/gear down the bottom of the screen. Note: depending on your device, you may need to scroll to reveal this menu. Tap the down arrow under "Type". Choose your battery type from the list – AGM, GEL, LFP (lithium) or WET. Next, it is important to set your battery capacity in amp hours (Ah). You can find this information printed on your battery. Tap the right arrow under "Capacity" to specify your battery capacity.
3. It is also recommended that you update your PM310-BT4J System to the latest firmware – this can be done by via the update function in the settings menu (your system may already be up to date). Please ensure you remain in close proximity to the system and do not disconnect power to the system or your phone during an update.
4. From the home screen, the PM310-BT4J app allows the user to remotely monitor key aspects of the power system from the convenience of their phone or tablet, as well as remotely switch on or off power to the output load, hot water system and water pump.

The following information is displayed in the app's home screen:

- House battery SOC, volts, amps, time remaining and temperature
- Charging mode/status
- Power input source (grid, solar/PV or VCR)
- Water tank levels (when sensors connected/installed/operational)
- Load, hot water system and water pump status and power buttons

The power button may be used to turn output load power on or off, resulting in startup or shutdown of all appliances and lighting wired to outputs on the PM335J-2 transformer.

NOTE: This switch only affects output load – the app will continue monitoring parameters and retain its Bluetooth connection to your smart device, even with the load off.

6.4 MAINTENANCE

6.4.1 Battery SOC Monitoring

The PM335J-2 transformer unit features built-in state of charge (SOC) monitoring for the house battery. To ensure accurate display of this information on the PMD-BT4J Monitor and in the app, the following conditions must be adhered to:

1. Battery capacity is set correctly in the PMD-BT4J Monitor or app – refer to your battery specifications.
2. When replacing a battery, ensure it is fully charged via AC mains for the first time.
3. Fully charge battery via AC mains at least once every 3 months, until the 'CHG' LED light on the PM335J-2 transformer unit remains on (solid) or 'float' shows on the monitor.

6.4.2 DAILY MAINTENANCE

- Ensure the Power Switch on the transformer unit is ON when you want to charge the battery with AC mains.
- Check the nominal battery voltage is 12VDC.
- Ensure there is space (10cm each side) beside the PM335J-2 unit for the appropriate ventilation.

7. TROUBLE SHOOTING

7.1 L.E.D Display on PM335J-2 Transformer Unit

No.	LED	COLOUR	STATUS	DESCRIPTION
1	Mains	Green	Quick flashing (flash twice every second)	AC input abnormal
2	Vehicle Bat	Green	Quick flashing (flash twice every second)	The vehicle battery is 2~13.4V or >16.0V, while AC power is connected.
3	Solar	Green	Quick flashing (flash twice every second)	Solar input voltage error – Solar Input >25Vdc
4	Fuse LED	Red	Solid	Fuse blown, need to check load and replace fuse
5	Fault	Red	ON	Short circuit
			Flash once per cycle	House battery voltage low
			Flash twice per cycle	House battery voltage high
			Flash 3 times per cycle	PM335J-2 unit over temp
			Flash 4 times per cycle	Bulk charge timeout
			Flash 5 times per cycle	VCR anomaly
Flash 6 times per cycle	Environment over temp			

Table 9 Error LED indicator of PM335J-2

7.2 Solving a 8032 fault with the PM335J-2 Remote App

If your system returns an 8032 fault, your lithium battery has returned a cell over-voltage protection and shut down charging. To correct, please set the 'Solar Abs Voltage' in your system settings to a lower value to prevent future warnings.



1: Select Battery Type Setting

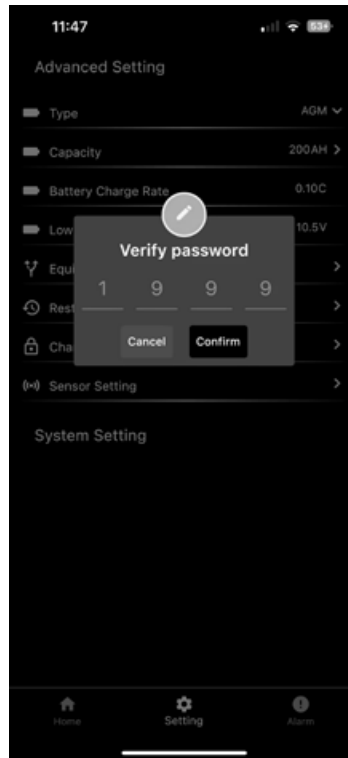

2: Input Password "1999"

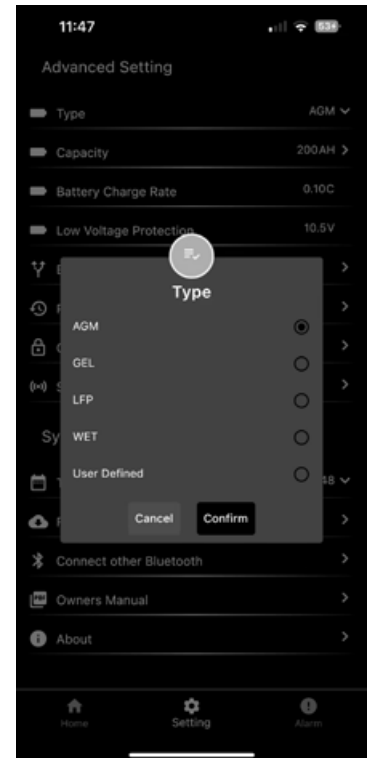

3: Select "User Defined" Type

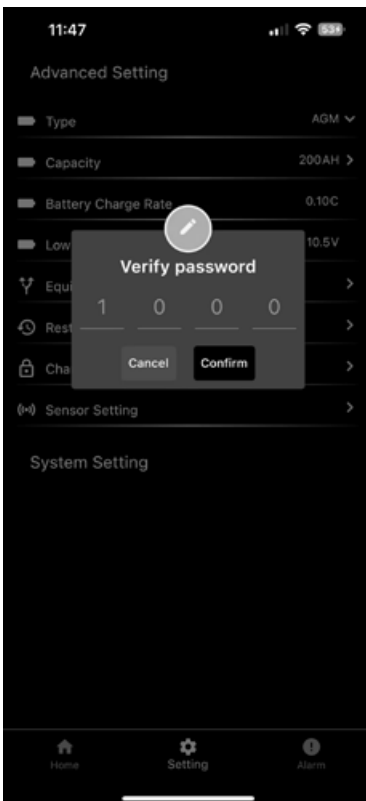

4: Input Password "1000"

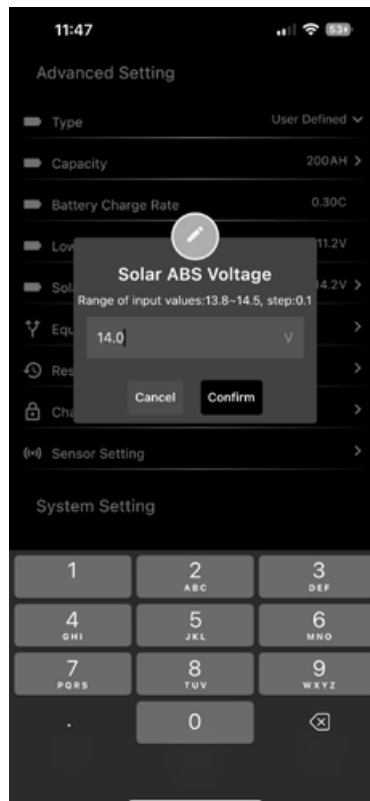

5: Set the Solar ABS Voltage

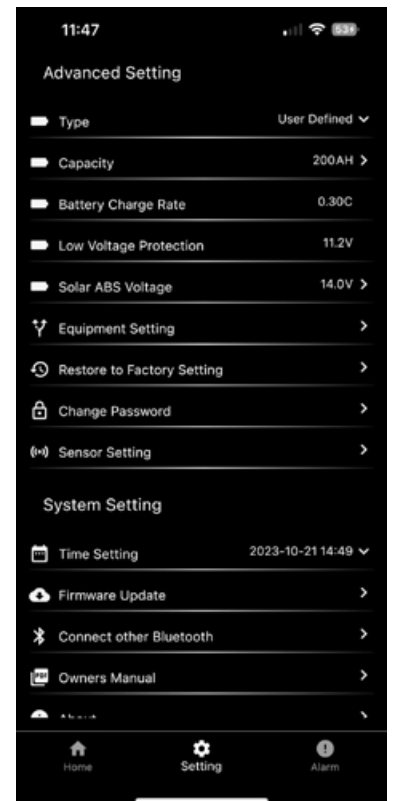

6: Change Successful

Figure 24 Fixing a 8032 cell over-voltage event

8. ADD-ON ACCESSORIES

8.1 PM335J-2 Accessory Range

The PM335J-2 transformer unit supports a range of additional Projecta accessories as listed below:

For details on how to connect these, refer to the connection diagram (Figure 25, page 22).

SC520/SC540

5 STAGE MPPT SOLAR CHARGER CONTROLLER WITH 100V INPUT

Get the most out of your solar array using these Maximum Power Point Tracking (MPPT) Solar controllers increasing the charging output by up to 30% (compared to PWM Solar controllers).



	20 AMP	60AMP
PART No.	SC520	SC540
Battery Voltage	12/24/48V	
Maximum Solar Voltage	100V	
Standby Current	1mA at 12V, 3mA at 24V, 5mA at 48V	
Charge Type	5 Stage	
Input	100V	
Output	20A	40A
Control Type	MPPT	
Batteries Supported	GEL, AGM, Wet, Lithium	
Temperature Compensation	-18mV/12V	
Communication	RS485, Bluetooth	
Storage Temperature	-40 – 70°C	
Humidity	5 – 95%	
IP Rating	IP31	
Weight	1.4Kg	
Cooling	Convection	

PMDCS30/PMDCS60

DC-DC 12V CHARGER

Smart DC to DC chargers specifically designed for Intelli-RV and Intelli-Grid.



	30 AMP	60AMP
PART No.	PMDCS30	PMDCS60
Charge Type	5 Stage	
Alternator Input Voltage	12 – 16V	
Output	12V, <30A	12V, <60A
Batteries Supported	Wet, GEL, AGM, Lithium	
Alternator Type	Smart & Conventional	
Storage Temperature	-40 – 70°C	
Operating Temperature	-40 – 70°C	
Temperature Compensation	-3mV/°C/Cell	
IP Rating	IP20	
Dimensions	181 x 148 x 52mm	
Weight	1.0Kg	
Cooling	Convection	
Smart Alternator	Turn on 12.2V Turn off 11.6V	
Conventional	Turn on 13.2V Turn off 12.8V	

PMDCS30-20

DC-DC 12V CHARGER

Smart DC to DC chargers specifically designed for Intelli-RV and Intelli-Grid where a 3 way fridge or compressor fridge are used.



PART No.	PMDCS30-20
Charge Type	5 Stage
Alternator Input Voltage	12 – 16V
Output	12V, <30A
Batteries Supported	Wet, GEL, AGM, Lithium
Alternator Type	Smart & Conventional
Storage Temperature	-40 – 70°C
Operating Temperature	-40 – 70°C
Temperature Compensation	-3mV/°C/Cell
IP Rating	IP20
Dimensions	181 x 148 x 52mm
Weight	1.0Kg
Cooling	Convection
Smart Alternator	Turn on 12.2V Turn off 11.6V
Conventional	Turn on 13.2V Turn off 12.8V

PMTMMS

TYRE PRESSURE MONITORING SYSTEM MODULE

The Tyre Pressure Monitoring System (TPMS) monitors the RV's tyre pressure before and during the journey.



PART No.	PMTMMS x 4 (one for each tyre)
PART No.	Receiver – PMTPMS-R
Input	6-24V
Working Current	30mA
Working Temperature	-40°C – 85°C
Humidity	<95%
Receiving Frequency	433.910Mhz
Wired Communication	RS48S
Weight	150g
PART No.	Sender – 4 x PMTPMS-S
Working Voltage	2.2 – 3.6V
Battery Type	CR1632
Transmitted Current	<5mA
Transmitted Power	<5dbm
Transmitted Frequency	433.910Mhz
Pressure Range	14 – 130PSI
Accuracy	± 1.45 PSI
Working Temperature	-30°C – 70°C
Weight	13.8g

PMLVL

LEVELLING SENSOR

Level the RV with the levelling sensor which can be monitored via the phone app.



Calibration

To calibrate the level sensor, the RV needs to be level in both forward and back and side to side. Once level, go to the Setting Page, select Level Sensor and press Calibrate. This will zero the sensor.

PART No.	PMLVL
Working Voltage	9 – 16V
Working Current	30mA
Working Temperature	-40°C – 85°C
IP Rating	IP20
Accuracy	± 2°

LB200-HDJ

12V HIGH DISCHARGE 200AH LITHIUM BATTERY

LB200-HD boast impressive capabilities and are ideal for 4WDs and caravans with high power demands.



PART No.	LB200-HDJ
Nominal Voltage	12.8V
Nominal Capacity	200ah
Nominal Energy	2560Wh
Charge Voltage	14.2V
Discharge Cut-Off Voltage	11.2V
Standard Charge Current	100 Amps
Maximum Charge Current	200 Amps
Maximum Discharge Current	200 Amps
Peak Discharge Current	300 Amps (10mins)
Operating Temperature	-20°C – 60°C
Maximum Number of Batteries In Parauel	4
Number Of Discharge Cycles	3000
Weight	22Kg
IP Rating	IP20

LB400-HDJ

12V HIGH DISCHARGE 400AH LITHIUM BATTERY

The LB400-HD boasts an astonishing 400Ah capacity and a market leading 300A discharge capability making it ideal to partner with high current drawing appliances such as 3000W inverters.



PART No.	LB400-HDJ
Nominal Voltage	12.8V
Nominal Capacity	400ah
Nominal Energy	2560Wh
Charge Voltage	14.2V
Discharge Cut-Off Voltage	11.2V
Standard Charge Current	100 Amps
Maximum Charge Current	200 Amps
Maximum Discharge Current	200 Amps
Peak Discharge Current	300 Amps (10mins)
Operating Temperature	-20°C – 60°C
Maximum Number of Batteries In Parauel	4
Number Of Discharge Cycles	3000
Weight	42.5Kg
IP Rating	IP20

8.2 Connecting & using Projecta add-on accessories

The PM310-BT4J system supports a range of additional Projecta devices including sensors, DCDC chargers and solar controllers listed on pages 20–21.

These devices are specifically designed to work with the Intelli-Jay systems to provide complete, real-time data of the systems performance on the APP or 4-inch display. Using the Projecta suite of accessories also ensures that each component is optimized to work with each other in a complete ecosystem and allows for easy diagnosis if any issues arise.

After installing the Projecta device to the system, visit the Configuration page to set up the device

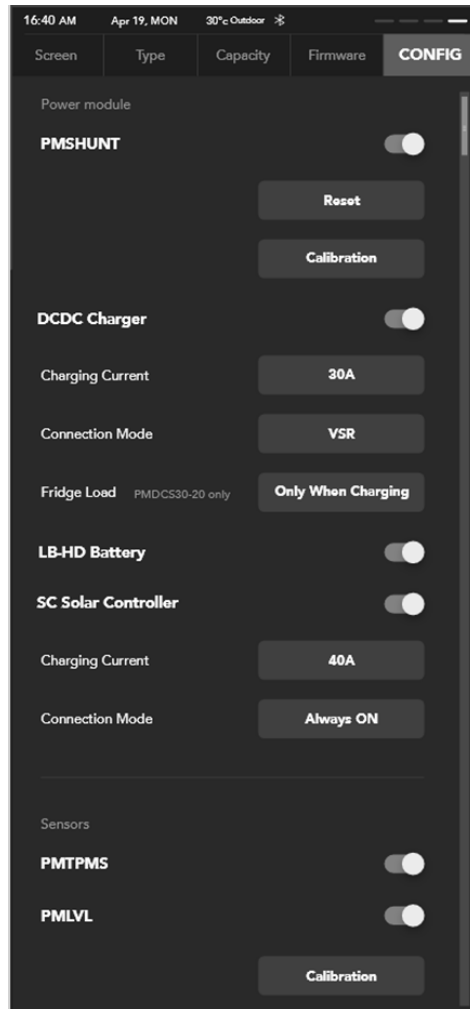

8.2.1 PMSHUNT

PMSHUNT is used for monitoring the status of the battery accurately in cases where the system incorporates an external inverter or any other load device connected directly to the battery.

“Active button”

If the system does not detect PMSHUNT during the activation stage, the 8901 error code will be displayed. If this occurs, check whether the PMSHUNT has been powered on, and whether the communication harness for PMSHUNT is connected correctly.

“Reset”

This feature is used when replacing the battery. PMSHUNT will set an initial SOC based on the current voltage. For accurate SOC, the battery must be charged until it reaches float status.

“Calibration”

This feature updates the SOC to 100% directly. It is used when the battery is fully charged but the SOC does not show 100%. Use this function to recalibrate the SOC directly to 100%.

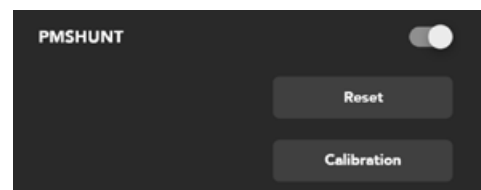

8.2.2 DC-DC CHARGER

The Projecta smart DC-DC range of chargers are specifically designed for Intelli-Jay power management systems. The range features the PMDCS30, PMDCS30-20, and PMDCS60. When connected to the Intelli-Jay system, the chargers communicate directly to the display to conveniently show VEH Input voltage, VEH charge current, and **FRIDGE – load draw (only if using PMDCS30-20)**

PMDCS30, PMDCS60 are booster chargers that allow charge currents of up to 30A or 60A

PMDCS30-20 is a dual output booster charger, with one output for auxiliary battery charging with charge current up to 30A, and the other dedicated to power a DC load (typically a DC fridge) with current up to 20A. When the vehicle engine is running, PMDCS30-20 will draw power from engine to charge the battery as well as to power the DC load; when vehicle engine is turned off, PMDCS30-20 will draw power from auxiliary battery to power the DC load. This ensures the connected DC load is always powered either by the vehicle's alternator or auxiliary battery.

“Active button”

After activating the DCDC Charger feature, the vehicles charging current can be viewed via the monitor.

“Charging current”

Select the appropriate charging current according to the vehicle's alternator power.

“Connection Mode”

VSR Mode: Connect the PMDCS output to the PM335J unit's Vehicle input. In this Mode, the Vehicle's charging current will run through PM335J unit.

PMSHUNT/LB-HD Mode. Connect the PMDCS output to the PMSHUNT or the LB-HD series battery directly.

“Fridge Load”

Only When Charging: The Fridge Load will only be available when the alternator is running (i.e., engine is switched on)

Constant ON: The Fridge Load will be always ON. When the vehicles engine is running, it will draw power from engine to charge the battery as well as to power Fridge load; when vehicle engine is turned off, it will draw power from auxiliary battery to power the fridge load

Note: This setting is only available for PMDCS30-20.

Constant ON will only function correctly when the PMDCS30-20 is connected directly to PMSHUNT or LB-HD series batteries. If connected via transformer VSR, this will shut down connection when VSR opens.

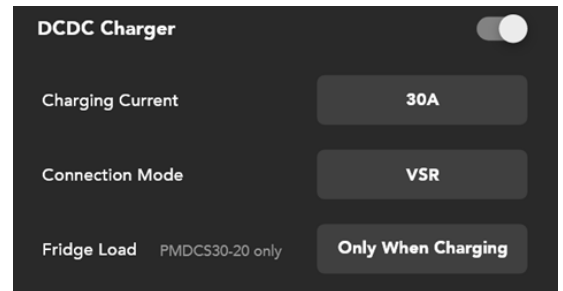

8.2.3 LB-HD BATTERIES

The Projecta LB-HD series lithium batteries are high-precision, high discharge current batteries. When connected to Intelli-Jay power management systems, the battery type and capacity are automatically recognised, and a custom charge algorithm is applied to ensure the optimum life cycle of the battery. Using a Projecta LB-HD battery also guarantees precise SOC and current of the battery on the monitor, which is vital in off-grid applications.

“Active button”

After activating LB-HD, the quantity of batteries needs to be set.

If the system shows 9401, please check if the communication cable from the battery to system is connected correctly.

If the system shows 9410, please check if the battery quantity is set correctly and check the communicate cable between battery to the systems is connected correctly.

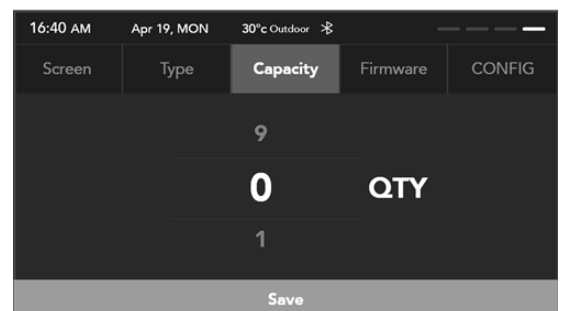

8.2.4 SC CHARGER

Get the most out of the caravan's solar array using The Projecta SC range of MPPT Solar charge controllers. Connect the output of the solar controller to the Battery directly instead of connecting to the PM335J unit.

"Active button"

After activating the SC solar controller, select the Connection Mode according to the SC dip switch configuration.

"Charging current"

Select the appropriate charging current according to the power of the solar panel(s) connected.

"Connection Mode"

Always ON: Powered by Battery. The unit will stay on as long as there is battery charge.

Low power: Powered by Solar. The unit will only stay on when there is Solar input

Note: SC series of solar regulators MUST be connected to either PMSHUNT or LB-HD series batteries to ensure current measurement and SOC accuracy is maintained.

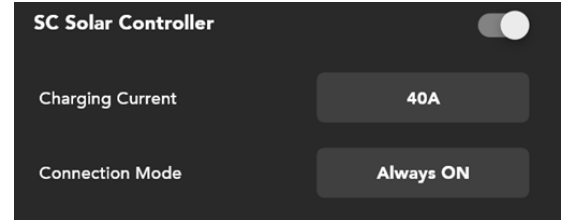

8.2.5 PMTPMS SENSOR

The Projecta PMTPMS is a smart tyre pressure sensor that monitors tyre pressure, ensuring that it is consistent and improving the overall life of the tyre.

"Active button"

After activating the PMSHUNT feature, if the system does not detect the PMTPMS, the 9301 error code will be displayed. If this occurs, check whether the PMTPMS is connected correctly.

The tyre pressure sensor should already be paired with the tyre pressure receiver from factory, the tyre pressure sensors simply need to be screwed directly onto the corresponding tyre.

Replacing the tyre pressure sensor.

When replacing the tyre pressure sensor, follow these steps:

1 Removing the sensor- On the APP or display press "Remove" on the corresponding sensor.

2 After a few seconds, the system will remove the data from the on the corresponding tyre. Click "Find Sensor".

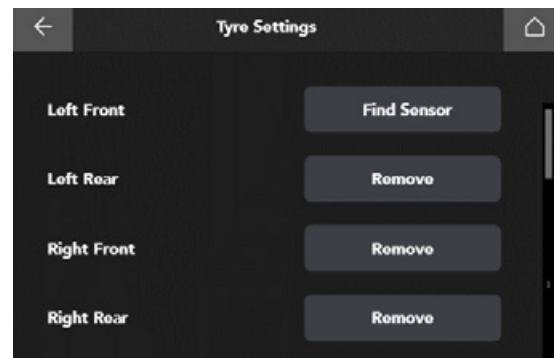
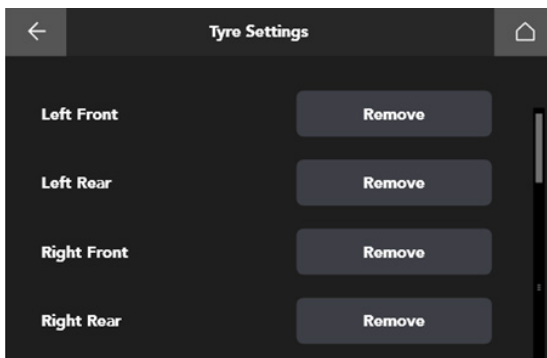

3 Screw the new tyre sensor into the tyre. When the following message pops up, it indicates that the sensor has been successfully paired.

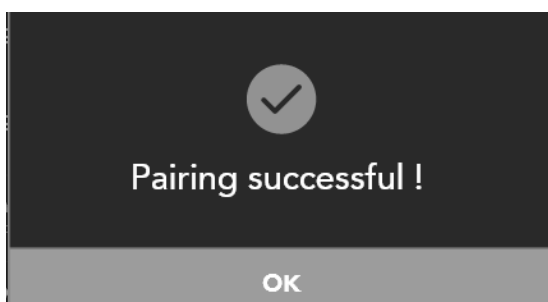

8.2.6 PMLVL SENSOR

PMLVL is a sensor for detecting the balance of the vehicle. This sensor detects the balance of the vehicle in real time to ensure ultimate safety and comfort.

“Active button”

After activating the PMSHUNT feature, if the system does not detect the PMLVL, the 9201 error code will be displayed. If this occurs, check whether the PMLVL is connected correctly.

“Calibration”

If the PMLVL cannot be mounted horizontally, the value displayed by the sensor will not be accurate. Use this function to force the PMLVL’s value to zero, and the PMLVL will use the current angle as a reference point.



9. SPECIFICATION

MODEL – PM335J-2		
ELECTRICAL SPECIFICATIONS		
Mains	Nominal input voltage (V)	240±10%VAC 50/60Hz
	Power factor	0.95
	Input current at full load	2.5A
Battery	Vehicle battery	12VDC
	Vehicle battery voltage range	12.8-16VDC
	House battery	12VDC
	House battery voltage range	10.5-16VDC
Solar	Charger type	MPPT
	Open circuit voltage	50VDC
	Max charging current	30A
	Maxium solar input	800W
Charging Relay	Relay specification	12VDC 60A continuous, peak current 100A, 30mins
	Connect voltage	Lead Acid - 13.4VDC LiFePO ₄ - 13.7VDC
	Connect delay time	10sec
	Disconnect voltage	Lead Acid - 12.8VDC LiFePO ₄ - 13.3VDC<2A
	Disconnect delay time	60sec
	High voltage limit	16.0VDC
Charger Mode	Charge Algorithms	5 Stage
	Battery type	AGM/GEL/LFP (LiFePO ₄)/WET/ User Defined
	Start voltage	2V for Lead Acid 0V for LFP
	Bulk current	30A (Max)
	Absorption voltage	(14.4/14.1 /14.2/14.7) ±0.15VDC
	Float voltage	(13.5/13.5 /13.5/13.7) ±0.13VDC
Power Supply Mode	Nominal output voltage	12.8±0.2 VDC
	Rated output current	35A (Continuous)
Efficiency		88%
Working temperature		-40°C~+65°C (50°C:full load; 60°C:20A; 65°C: shutdown the output)

MODEL – PM335J-2			
ELECTRICAL SPECIFICATIONS			
Battery Disconnect (LVD)	Disconnect voltage	AGM/GEL/WET	10.5VDC (default)
		LFP (LiFePO ₄)	11.2 VDC (Default)
	Delay off time	60 sec	
	Reconnect voltage	AGM/GEL/WET	11.5VDC (default)
LFP (LiFePO ₄)		12.2 VDC (Default)	
Current draw on Battery	240VAC is off, no vehicle charging	330mA	
	Load switch off	255mA	
	LVD off, Service<10.5V current draw on battery	180mA	
	Battery switch OFF <10V draw on battery	0mA	
Fused outputs	Numbers	14	
	Rated Current	10A x 11, 15A x 3	
Protection	Short circuit on output	Fuse blown	
	Reverse polarity	Diode reverse isolation	
	Overload protection	Derate the output until overload is removed	
	Battery charger over temperature	Shut down PM335J-2	
	Ambient over temperature	Alarm	
	Battery over voltage limits	Battery charger disconnect, loads disconnect	
PHYSICAL SPECIFICATIONS			
Dimensions (L*W*H)	264 × 164 × 128mm		
Weight	3kgs		
Enclosure	Steel Case		
Battery Connector	M4 Screw (16mm ²)		
Load Connector	Wago804-114 (2.5mm ²)	Wago2706-103 (6mm ²)	
Cooling	Forced cooling		
Protection category	IP20		
Approvals			
Electrical	AS/NZS 60335.2.29		
EMC	CISPR14		

Table 10 Specification of PM335J-2

WARRANTY STATEMENT

Applicable only to product sold in Australia

Brown & Watson International Pty Ltd of 1500 Ferntree Gully Road, Knoxfield, Vic., telephone (03) 9730 6000, fax (03) 9730 6050, warrants that all products described in its current catalogue (save and except for all bulbs and lenses whether made of glass or some other substance) will under normal use and service be free of failures in material and workmanship for a period of three (3) years (unless this period has been extended as indicated elsewhere) from the date of the original purchase by the consumer as marked on the invoice. This warranty does not cover ordinary wear and tear, abuse, alteration of products or damage caused by the consumer.

To make a warranty claim the consumer must deliver the product at their cost to the original place of purchase or to any other place which may be nominated by either BWI or the retailer from where the product was bought in order that a warranty assessment may be performed. The consumer must also deliver the original invoice evidencing the date and place of purchase together with an explanation in writing as to the nature of the claim.

In the event that the claim is determined to be for a minor failure of the product then BWI reserves the right to repair or replace it at its discretion. In the event that a major failure is determined the consumer will be entitled to a replacement or a refund as well as compensation for any other reasonably foreseeable loss or damage. This warranty is in addition to any other rights or remedies that the consumer may have under State or Federal legislation.

IMPORTANT NOTE

Our goods come with guarantees that cannot be excluded under the Australian Consumer Law. You are entitled to a replacement or refund for a major failure and compensation for any other reasonably foreseeable loss or damage. You are also entitled to have the goods repaired or replaced if the goods fail to be of acceptable quality and the failure does not amount to a major failure.

Distributed by

AUSTRALIA

Brown & Watson International Pty Ltd

Knoxfield Victoria 3180

Telephone (03) 9730 6000

Facsimile (03) 9730 6050

National Toll Free 1800 294 294

NEW ZEALAND

Brown & Watson International NZ Ltd

Mount Wellington Auckland 1060

Telephone (09) 525 4575

IS583

Issue 1 11/2023