

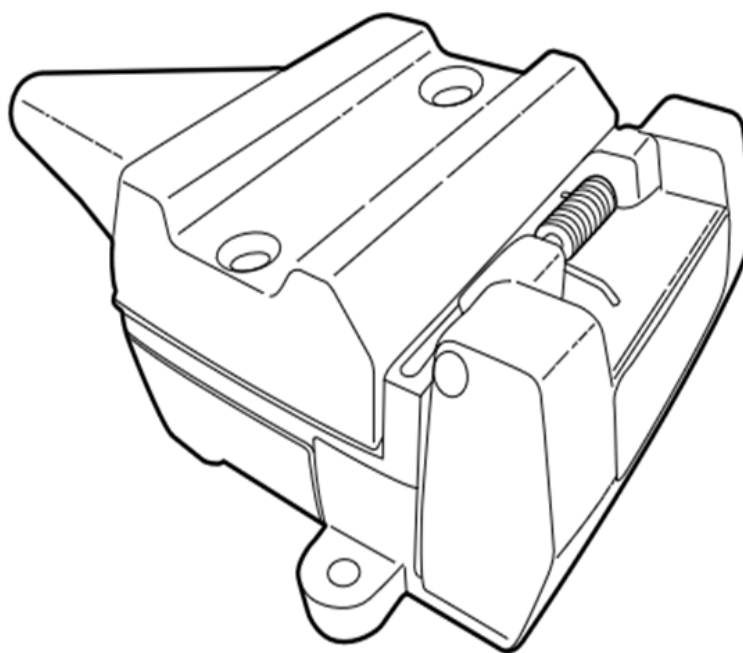

TOWABLE



Various Models with 12-pin



TOW VEHICLE WIRING INSTRUCTIONS



GENERAL NOTES

- Read through the fitting instructions before installation.
- Always install the accessory following the fitting instructions. Failure to do so may cause damage to the vehicle or accessory.
- Ensure all recyclable discarded vehicle accessory components and packaging are recycled following local recycling regulations.
- It is always recommended that this accessory is fitted by a qualified technician.
- Safely store and protect any removed vehicle components.
- Remove all metal swarf and dust from all vehicle surfaces if surface is used for accessory installation.

SAFETY NOTES

- Check that all work practices comply with safety standards.
- Please wear appropriate clothing and use safety equipment.



FITTING TIME



30minutes

PARTS REQUIRED



12 Pin Flat Trailer Socket



50A Grey Anderson Plug



Phillips Head Screw Driver



Heat Gun



Wire Cutters



Adhesive Tape



Wire Strippers



Jewellers Flat Head Screw Driver



Soldering Iron



10mm Heat Shrink



JAYCO TOWABLE

(VIEW WITH LID OPEN)



Below is a table listing each pin, what circuit to connect to on the towing vehicle, and the minimum wire size to be used.

Pin#	Function	Colour	Min Wire Size (T)		Special Connection Instructions
			Mm2	AWG	
1	Left Indicator	Yellow	1.25	16	-
2	Reverse	Black	1.25	16	-
3	Ground	White	3.0	12	Connect to vehicle chassis ground point. Do not connect to trailer harness ground wire. Do not connect directly to negative battery terminal.
4	Right Indicator	Green	1.25	16	-
5	Electric Brakes	Blue	2.0	14	Connect to Electric Brake Controller
6	Stop Lamp	Red	1.25	16	-
7	Tail Lamps	Brown	1.25	16	-
8	+12V Supply from Battery	Orange	5.0	10	Connect directly to vehicle battery positive terminal with a 40A fast acting fuse
9	Not Connected	-	-	-	-
10	Ground	White	5.0	10	Connect directly to vehicle battery negative terminal or vehicle chassis ground point
11	Not Connected	-	-	-	-
12	Not Connected	-	-	-	-



It is critical that the correct wire size is used for each wire, otherwise damage could occur to the vehicle and caravan wiring. Consult a qualified auto electrician if you are unsure.

STEP 1

Pins 1, 2, 3, 4, 5, 6 & 7 will likely be connected through the towing vehicles existing trailer wiring, and the wires can simply be removed from the existing vehicle trailer socket and housed in the correct pins on the supplied 12-pin socket.

Note: Consult your vehicle dealer or a qualified auto electrician if you are unsure.

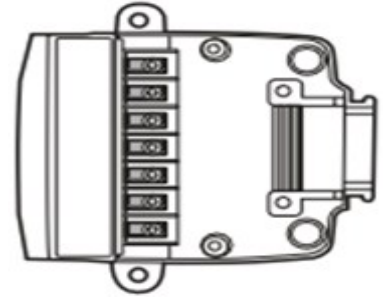

STEP 2

Pins 8 & 10 must be connected directly to the towing vehicle battery, refer to the table on page 3 above for minimum wire size required. Pin 8 wire should be fused with a 40A fuse as close to the vehicle battery as possible.

Note: Do not connect Pin 8 to any other existing power circuit on the vehicle. This could cause damage to the vehicle wiring. Consult your vehicle dealer or a qualified auto electrician if you are unsure.

Note: A fast acting 40A fuse must be used and mounted as close to the battery as possible.

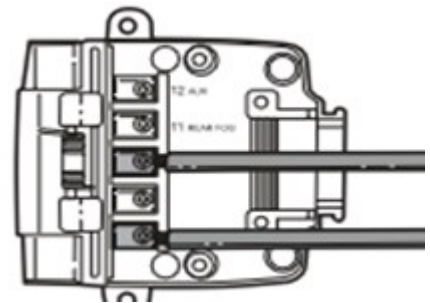

STEP 3

It is recommended that a voltage-sensing battery isolator relay is also installed in series with both the fridge +12V battery supply on grey Anderson Plug and the standard 12V supply on Pin 8 in order to prevent the caravan from draining the towing vehicle battery. Both circuits can be connected as close to the vehicle battery as possible.—refer to the relay manufacturer instructions for exact installation requirements.

Note: Consult your vehicle dealer or qualified auto electrician if you are unsure.

STEP 4

Connect the caravan to the towing vehicle and test all caravan lamps and other electrical device for correct operation

NOTES

The auxiliary circuit on Pin 8 and 10 provide power to the Jayco Recreational Vehicle for the Lippert Sway Command, Tyre Pressure Monitoring System (TPMS), wireless rear-view camera and the Jayco "House" Battery if DC-DC is not optioned. In addition, the auxiliary circuit will inhibit the activation of the slide-out and electric awning.

Lippert ABS system uses the following pins of the 12-pin plug— Pin 3= Ground, Pin 5 = Electric Brakes and Pin 8 = 12V Power Supply.

*GREY ANDERSON PLUG

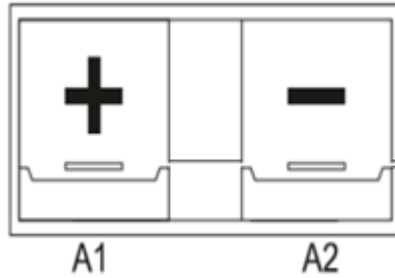

ONLY APPLICABLE IF EQUIPPED WITH 3-WAY FRIDGE. CHECK SPEC SHEET TO CONFIRM

Pin#	Function	Colour	Min Wire Size (T)		Special Connection Instructions
			Mm2	AWG	
A1	Fridge 12v Supply	Red	10	7	Connect from starter battery 30A fast acting fuse
A2	Fridge Ground	Black	10	7	Connect to starter battery negative terminal or chassis ground

The grey Anderson plug pin must be connected directly to the towing vehicle battery, refer to table above for minimum wire size required. The (+) wire should be fused with a 30A fuse as close to the vehicle battery as possible. At the grey Anderson plug end, the pins must be crimped and soldered onto the wires before fitting the wires to the grey Anderson plug.

Note: Do not connect the positive (+) to any other existing power circuit on the vehicle. This could cause damage to the vehicle wiring. Consult your vehicle dealer or a qualified auto electrician if you are unsure.

Note: A fast acting 30A fuse must be used and mounted as close to the battery as possible.

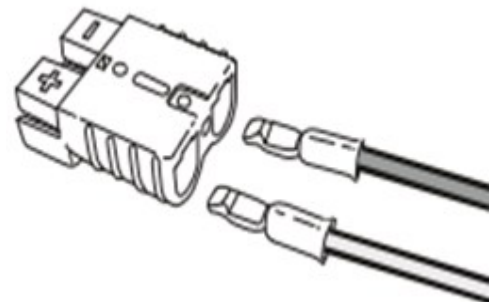

*RED ANDERSON PLUG

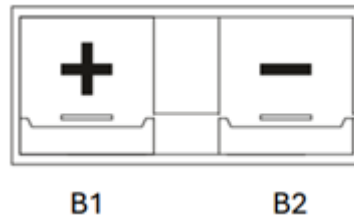

ONLY APPLICABLE IF EQUIPPED WITH DC-DC CHARGER. CHECK SPEC SHEET TO CONFIRM

Pin#	Function	Colour	Min Wire Size (T)		Special Connection Instructions
			Mm2	AWG	
B1	DC-DC Charger 12v Supply	Red	10	7	Connect from starter battery/VSR with a 100A fuse Max. Refer to vehicle manufacturer recommendation regarding the need of installing battery isolator unit such as VSR (Voltage Sensitive Relay).
B2	DC-DC Charger Ground	Black	10	7	Connect to starter battery negative terminal or chassis ground.

For Jayco Recreational Vehicles that have DC/DC Booster installed, a separate line of power is supplied. The DC/DC Booster will be supplied via a red Anderson plug with a 10mm² cable pair mounted on the left-hand side of the A-frame.

The Anderson plug pin on the towing vehicle must be connected directly to the towing vehicle's battery via separate voltage sensing relay with a current rating of at least 40A. The minimum wire size for this circuit is 10mm². The (+) cable must be fused with a 40A fuse as close to the towing vehicle's battery as possible. At the red Anderson plug end, the pins must be crimped and soldered onto the wires before fitting the wires into the red Anderson plug.

Note: Do not connect the positive (+) to any other existing power circuit on the vehicle. This could cause damage to the vehicle wiring. Consult your vehicle dealer or a qualified auto electrician if you are unsure.

